

Accessories For Precision Tool Holders & Tapping Chucks

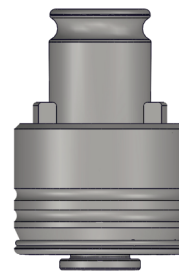

INDEX

Sr. No.	Contents		Page No.
1	Precision Keyless Drill Chuck & Arbor (DIN 228 B)		219
2	ER Nuts & Spanners <ul style="list-style-type: none"> ER Series Nuts for Collet Chucks (DIN 6499) Spanners for ER Series Collet Chucks Spanner for NC Drill Chuck (NCDC) Spanners for Power Milling Chuck (PMC) ER Series Sealed Nuts for Collet Chucks (DIN 6499) 	 	220 - 221 222 223 224 - 225
3	Sealing Disc for ER Series Sealed Nuts		226 - 231
4	Accessories for HSK Holders <ul style="list-style-type: none"> Coolant Tube for HSK-A Spanner for HSK-A Sealing Plug for HSK-A 	 	232
5	Collets <ul style="list-style-type: none"> Collet ER (DIN 6499) Tap Collet ER-G Collet DMC Reduction Sleeve (RS) Quick Change Tap Collet (QCTC) 	 	233 - 237 238 - 240 241 242 243 - 251
6	Quick Change Tap Adaptor <ul style="list-style-type: none"> KWE KWES.. / B KWESK.. / B KWRE 	 	252 - 259 260 - 276 277 - 279 280
7	Technical Information <ul style="list-style-type: none"> Tap Shank Dimensions (ISO 529 / DIN / JIS / ANSI) Recommended Torque Values 		281 - 284
8	Pull Studs <ul style="list-style-type: none"> BT / ISO / MAZAK / SK 		285 - 287

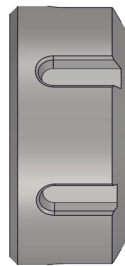
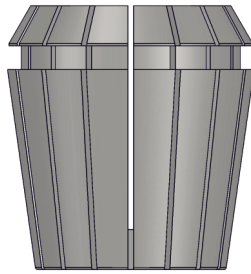
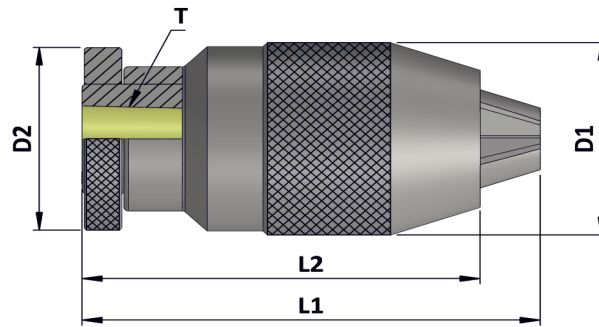

Precision Key Less Drill Chuck

Item Name	Item Code	D1	D2	T	L1	L2
DC 0 - 6.5 B12	K10150246301127	34	34	B12	68	61.5
DC 0 - 6.5 J1	K10150247301127	34	34	J1	68	61.5
DC 1 - 13 B16	K10151249301127	50	48	B16	103	90.5
DC 1 - 13 J6	K10151160301127	50	48	J6	103	90.5

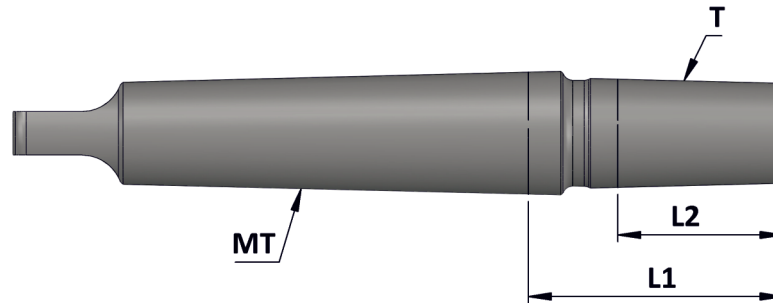

Precision Arbor (DIN 228 B)

Item Name	Item Code	T	Morse Tapre (MT)	L1	L2
ARBOR MT1B J1	K10198496318127	J1	MT 1	27.7	16.7
ARBOR MT2B J1	K10198373318127	J1	MT 2	29.5	16.7
ARBOR MT2B J6	K10198373319127	J6	MT 2	38.5	25.4

Note: All Dimensions are in mm

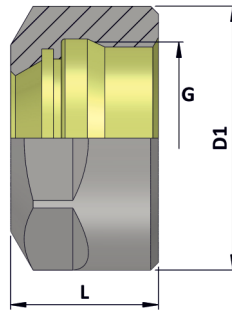

Hex. Nut ER

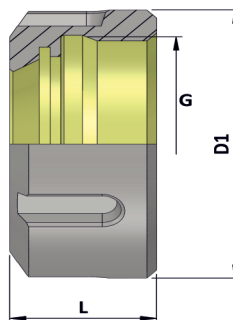
Item Name	Item Code	D1	G	L	Suitable Spanner
UM ER 11 HEX	K10183273271139	19	M14 x 0.75	11.3	GS 17
UM ER 16 HEX	K10183273272139	28	M22 x 1.50	17.5	GS 25
UM ER 20 HEX	K10183150541127	34	M25 x 1.50	19	GS 30

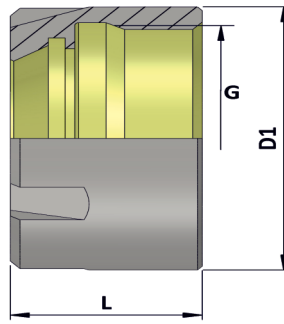

UM ER Slotted Nut

Item Name	Item Code	D1	G	L	Suitable Spanner
UM ER 16 SLOTTED	K10183273272134	32	M22 x 1.5	17.50	E16
UM ER 20 SLOTTED	K10183273273134	35	M25 x 1.5	19	E20
UM ER 25 SLOTTED	K10183273274134	42	M32 x 1.5	20	E25
UM ER 32 SLOTTED	K10183273275134	50	M40 x 1.5	22.50	E32
UM ER 40 SLOTTED	K10183273276134	63	M50 x 1.5	25.50	E40
UM ER 50 SLOTTED	K10183273277134	78	M64 x 2	35	E50

Note: All Dimensions are in mm

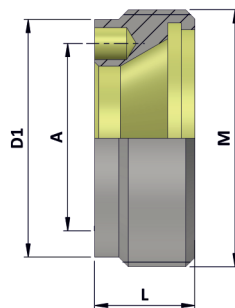

UM ER M Slotted Nut

Item Name	Item Code	D1	G	L	Suitable Spanner
UM ER 8 M	K10183273270136	12	M10 x 0.75	11	E8M
UM ER 11 M	K10183273271136	16	M13 x 0.75	11.50	E11M
UM ER 16 M	K10183273272136	22	M19 x 1.0	17.50	E16M
UM ER 20 M	K10183273273136	28	M24 x 1.0	19	E20M
UM ER 25 M	K10183273274136	35	M30 x 1.0	20	E25M

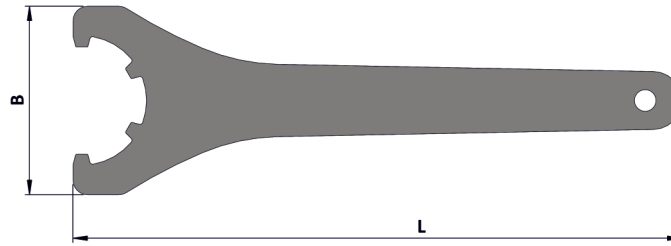

UM ER A Nut

Item Name	Item Code	D1	A	M	L	Suitable Spanner
UM ER 25 A	K10183243301127	29.50	23.60	M32 x 1.5	12.5	E25A
UM ER 32 A	K10183244301127	37	31.85	M40 x 1.5	18.5	E32A

Note: All Dimensions are in mm

Spanner Type (E)

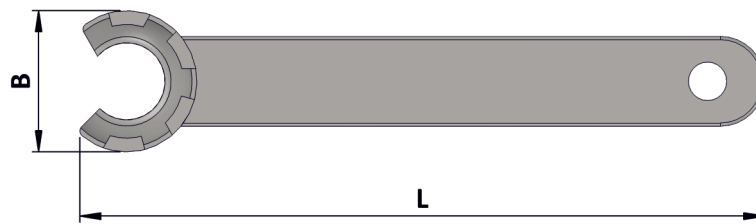
Item Name	Item Code	B	L	Suitable Nut
SPANNER E16	K10184355301127	50	160	UM/ER16
SPANNER E20	K10184356301127	55	180	UM/ER20
SPANNER E25	K10184357301127	65	210	UM/ER25
SPANNER E32	K10184358301127	75	250	UM/ER32
SPANNER E40	K10184359301127	90	290	UM/ER40
SPANNER E50	K10184360301127	110	350	UM/ER50

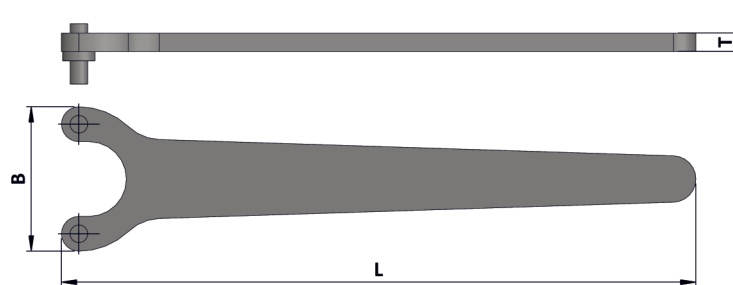

Spanner Type (EM) (Mini)

Item Name	Item Code	B	L	Suitable Nut
SPANNER E 8M	K10184398301127	12.4	70	UM/ER8M
SPANNER E11M	K10184399301127	16.8	90	UM/ER11M
SPANNER E16M	K10184400301127	22.5	110	UM/ER16M
SPANNER E20M	K10184401301127	29	120	UM/ER20M
SPANNER E25M	K10184402301127	36	130	UM/ER25M

Spanner Type (ER A)

Item Name	Item Code	T	B	L	Suitable Nut
SPANNER E25 A	K10184487301127	4	31	130	UM/ER25A
SPANNER E32 A	K10184488301127	5	42	150	UM/ER32A

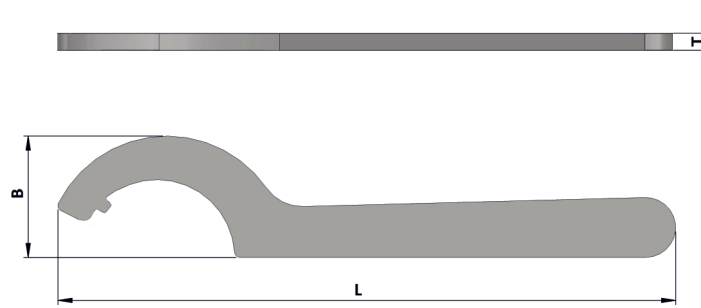
Note: All Dimensions are in mm



Spanner For (NCDC)

Item Name	Item Code	T	B	L	Suitable Chuck
SPANNER for NCDC	K10184167301127	5	48	176	NCDC 1-13

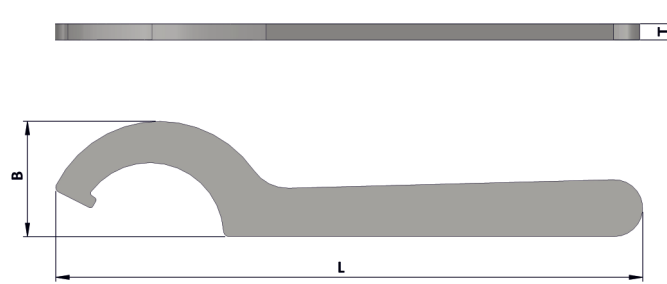

Spanner For (PMC)

Item Name	Item Code	T	B	L	Suitable Chuck
SPANNER C-20	K10184445301127	6	42.50	216	PMC C-20
SPANNER C-32	K10184446301127	6	53	288	UM/ER32A

Note: All Dimensions are in mm

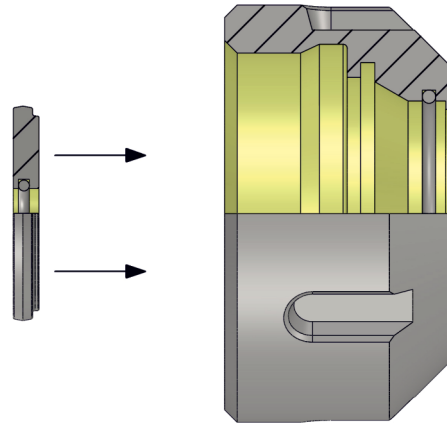

Technical Information :

Sealing Nuts along with Sealing Disc has a compact design with very short extension of clamping nuts which gives the following benefits.

- 1) It protects against all kind of dirt and chips entering the slots of the collet.
- 2) Coolant through tools can be used, which gives improved cooling and lubrication of tools and hence increases the tool life.
- 3) Improved chip removal.
- 4) Sealing Disc are available from $\varnothing 3.0$ mm in range of 0.5mm. Hence easy changing of Sealing Disk according to required application.
- 5) No need of expensive sealed collets. Regular collets are best suitable.

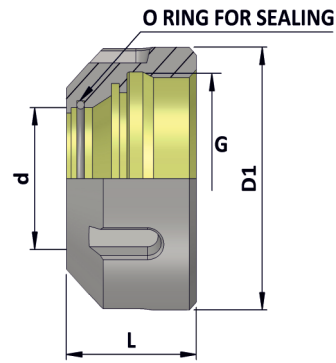

UM ER Sealed Nut

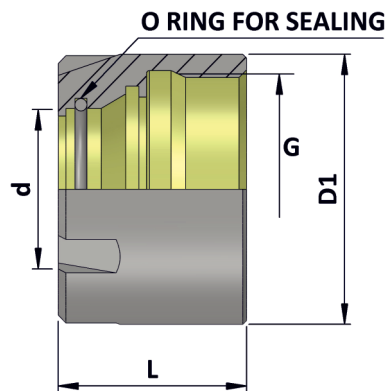
Item Name	Item Code	d	D1	G	L	Suitable Spanner
UM ER 16 S	K10183273272135	13	32	M22 x 1.5	22.5	E16
UM ER 20 S	K10183273273135	16	35	M25 x 1.5	24	E20
UM ER 25 S	K10183273274135	21	42	M32 x 1.5	25	E25
UM ER 32 S	K10183273275135	27	50	M40 x 1.5	27.5	E32
UM ER 40 S	K10183273276135	33.5	63	M50 x 1.5	30.5	E40
UM ER 50 S	K10183273277135	43.5	78	M64 x 2	42.5	E50

UM ER M Sealed Nut

Item Name	Item Code	d	D1	G	L	Suitable Spanner
UM ER 16 MS	K10183273272137	13	22	M19 x 1.0	22	E16M
UM ER 20 MS	K10183273273137	16	28	M24 x 1.0	24	E20M
UM ER 25 MS	K10183273274137	21	35	M30 x 1.0	25	E25M

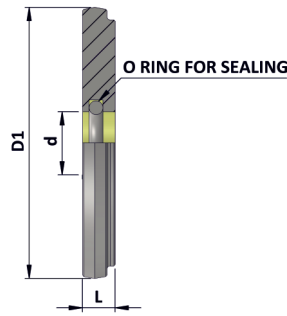
Note: All Dimensions are in mm



Technical Information

Item Name	D1	Holding Rang (d)	L
SEALING DISC ER 16	13	3.0 - 10	4
SEALING DISC ER 20	16	3.0 - 13	4
SEALING DISC ER 25	21	3.0 - 16	4
SEALING DISC ER 32	27	3.0 - 20	4
SEALING DISC ER 40	33	3.0 - 26	4
SEALING DISC ER 50	43.5	6 - 32.5	4.5

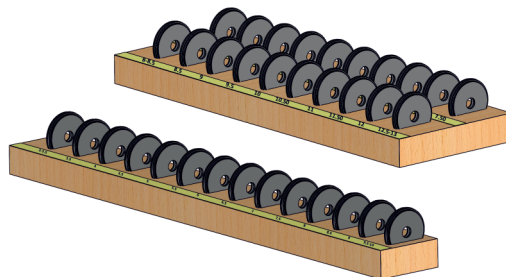

Set Of Sealing Disc

Item Name	Item Code	Clamping Range	PCS / SET
SET OF SEALING DISC ER 16 3.0 - 10MM	K10256149294127	3.0 - 10	14 Nos
SET OF SEALING DISC ER 20 3.0 - 13MM	K10256150295127	3.0 - 13	20 Nos
SET OF SEALING DISC ER 25 3.0 - 16MM	K10256151296127	3.0 - 16	26 Nos
SET OF SEALING DISC ER 32 3.0 - 20MM	K10256152297127	3.0 - 20	34 Nos
SET OF SEALING DISC ER 40 3.0 - 26MM	K10256153298127	3.0 - 26	46 Nos

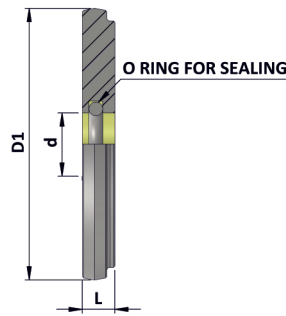

Sealing Disc ER 16

Item Name	Item Code	Suitable Nut	d	D1	L	'O' Ring Size
SEALING DISC ER 16 3.00 - 3.50	K10152149185127	ER 16 S / ER 16 MS	3.00 - 3.50	13	4	2.80X1.50
SEALING DISC ER 16 3.50 - 4.00	K10152149186127	ER 16 S / ER 16 MS	3.50 - 4.00	13	4	3.30X1.50
SEALING DISC ER 16 4.00 - 4.50	K10152149187127	ER 16 S / ER 16 MS	4.00 - 4.50	13	4	3.80X1.50
SEALING DISC ER 16 4.50 - 5.00	K10152149188127	ER 16 S / ER 16 MS	4.50 - 5.00	13	4	4.30X1.50
SEALING DISC ER 16 5.00 - 5.50	K10152149189127	ER 16 S / ER 16 MS	5.00 - 5.50	13	4	4.80X1.50
SEALING DISC ER 16 5.50 - 6.00	K10152149190127	ER 16 S / ER 16 MS	5.50 - 6.00	13	4	5.30X1.50
SEALING DISC ER 16 6.00 - 6.50	K10152149191127	ER 16 S / ER 16 MS	6.00 - 6.50	13	4	5.80X1.50
SEALING DISC ER 16 6.50 - 7.00	K10152149192127	ER 16 S / ER 16 MS	6.50 - 7.00	13	4	6.30X1.50
SEALING DISC ER 16 7.00 - 7.50	K10152149193127	ER 16 S / ER 16 MS	7.00 - 7.50	13	4	6.80X1.50
SEALING DISC ER 16 7.50 - 8.00	K10152149194127	ER 16 S / ER 16 MS	7.50 - 8.00	13	4	7.30X1.50
SEALING DISC ER 16 8.00 - 8.50	K10152149195127	ER 16 S / ER 16 MS	8.00 - 8.50	13	4	7.80X1.50
SEALING DISC ER 16 8.50 - 9.00	K10152149196127	ER 16 S / ER 16 MS	8.50 - 9.00	13	4	8.30X1.50
SEALING DISC ER 16 9.00 - 9.50	K10152149197127	ER 16 S / ER 16 MS	9.00 - 9.50	13	4	8.80X1.0
SEALING DISC ER 16 9.50 - 10.00	K10152149198127	ER 16 S / ER 16 MS	9.50 - 10.00	13	4	9.30X1.0

Sealing Disc ER 20

SEALING DISC ER 20 3.00 - 3.50	K10152150185127	ER 20 S / ER 20 MS	3.00 - 3.50	16	4	2.80X1.50
SEALING DISC ER 20 3.50 - 4.00	K10152150186127	ER 20 S / ER 20 MS	3.50 - 4.00	16	4	3.30X1.50
SEALING DISC ER 20 4.00 - 4.50	K10152150187127	ER 20 S / ER 20 MS	4.00 - 4.50	16	4	3.80X1.50
SEALING DISC ER 20 4.50 - 5.00	K10152150188127	ER 20 S / ER 20 MS	4.50 - 5.00	16	4	4.30X1.50
SEALING DISC ER 20 5.00 - 5.50	K10152150189127	ER 20 S / ER 20 MS	5.00 - 5.50	16	4	4.80X1.50
SEALING DISC ER 20 5.50 - 6.00	K10152150190127	ER 20 S / ER 20 MS	5.50 - 6.00	16	4	5.30X1.50
SEALING DISC ER 20 6.00 - 6.50	K10152150191127	ER 20 S / ER 20 MS	6.00 - 6.50	16	4	5.80X1.50
SEALING DISC ER 20 6.50 - 7.00	K10152150192127	ER 20 S / ER 20 MS	6.50 - 7.00	16	4	6.30X1.50
SEALING DISC ER 20 7.00 - 7.50	K10152150193127	ER 20 S / ER 20 MS	7.00 - 7.50	16	4	6.80X1.50
SEALING DISC ER 20 7.50 - 8.00	K10152150194127	ER 20 S / ER 20 MS	7.50 - 8.00	16	4	7.30X1.50
SEALING DISC ER 20 8.00 - 8.50	K10152150195127	ER 20 S / ER 20 MS	8.00 - 8.50	16	4	7.80X1.50
SEALING DISC ER 20 8.50 - 9.00	K10152150196127	ER 20 S / ER 20 MS	8.50 - 9.00	16	4	8.30X1.50
SEALING DISC ER 20 9.00 - 9.50	K10152150197127	ER 20 S / ER 20 MS	9.00 - 9.50	16	4	8.80X1.50
SEALING DISC ER 20 9.50 - 10.00	K10152150198127	ER 20 S / ER 20 MS	9.50 - 10.00	16	4	9.30X1.50
SEALING DISC ER 20 10.00 - 10.50	K10152150199127	ER 20 S / ER 20 MS	10.00 - 10.50	16	4	9.80X1.50
SEALING DISC ER 20 10.50 - 11.00	K10152150200127	ER 20 S / ER 20 MS	10.50 - 11.00	16	4	10.30X1.50
SEALING DISC ER 20 11.00 - 11.50	K10152150201127	ER 20 S / ER 20 MS	11.00 - 11.50	16	4	10.80X1.50
SEALING DISC ER 20 11.50 - 12.00	K10152150202127	ER 20 S / ER 20 MS	11.50 - 12.00	16	4	11.30X1.50
SEALING DISC ER 20 12.00 - 12.50	K10152150203127	ER 20 S / ER 20 MS	12.00 - 12.50	16	4	11.80X1.0
SEALING DISC ER 20 12.50 - 13.00	K10152150204127	ER 20 S / ER 20 MS	12.50 - 13.00	16	4	12.30X1.0

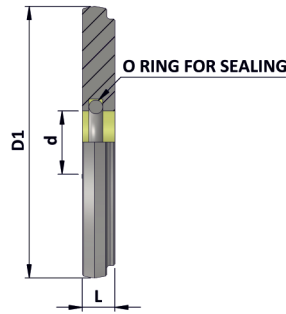
Note: All Dimensions are in mm

Sealing Disc ER 25

Item Name	Item Code	Suitable Nut	d	D1	L	'O' Ring Size
SEALING DISC ER 25 3.00 - 3.50	K10152151185127	ER 25 S / ER 25 MS	3.00 - 3.50	21	4	2.80X1.50
SEALING DISC ER 25 3.50 - 4.00	K10152151186127	ER 25 S / ER 25 MS	3.50 - 4.00	21	4	3.30X1.50
SEALING DISC ER 25 4.00 - 4.50	K10152151187127	ER 25 S / ER 25 MS	4.00 - 4.50	21	4	3.80X1.50
SEALING DISC ER 25 4.50 - 5.00	K10152151188127	ER 25 S / ER 25 MS	4.50 - 5.00	21	4	4.30X1.50
SEALING DISC ER 25 5.00 - 5.50	K10152151189127	ER 25 S / ER 25 MS	5.00 - 5.50	21	4	4.80X1.50
SEALING DISC ER 25 5.50 - 6.00	K10152151190127	ER 25 S / ER 25 MS	5.50 - 6.00	21	4	5.30X1.50
SEALING DISC ER 25 6.00 - 6.50	K10152151191127	ER 25 S / ER 25 MS	6.00 - 6.50	21	4	5.80X1.50
SEALING DISC ER 25 6.50 - 7.00	K10152151192127	ER 25 S / ER 25 MS	6.50 - 7.00	21	4	6.30X1.50
SEALING DISC ER 25 7.00 - 7.50	K10152151193127	ER 25 S / ER 25 MS	7.00 - 7.50	21	4	6.80X1.50
SEALING DISC ER 25 7.50 - 8.00	K10152151194127	ER 25 S / ER 25 MS	7.50 - 8.00	21	4	7.30X1.50
SEALING DISC ER 25 8.00 - 8.50	K10152151195127	ER 25 S / ER 25 MS	8.00 - 8.50	21	4	7.80X1.50
SEALING DISC ER 25 8.50 - 9.00	K10152151196127	ER 25 S / ER 25 MS	8.50 - 9.00	21	4	8.30X1.50
SEALING DISC ER 25 9.00 - 9.50	K10152151197127	ER 25 S / ER 25 MS	9.00 - 9.50	21	4	8.80X1.50
SEALING DISC ER 25 9.50 - 10.00	K10152151198127	ER 25 S / ER 25 MS	9.50 - 10.00	21	4	9.30X1.50
SEALING DISC ER 25 10.00 - 10.50	K10152151199127	ER 25 S / ER 25 MS	10.00 - 10.50	21	4	9.80X1.50
SEALING DISC ER 25 10.50 - 11.00	K10152151200127	ER 25 S / ER 25 MS	10.50 - 11.00	21	4	10.30X1.50
SEALING DISC ER 25 11.00 - 11.50	K10152151201127	ER 25 S / ER 25 MS	11.00 - 11.50	21	4	10.80X1.50
SEALING DISC ER 25 11.50 - 12.00	K10152151202127	ER 25 S / ER 25 MS	11.50 - 12.00	21	4	11.30X1.50
SEALING DISC ER 25 12.00 - 12.50	K10152151203127	ER 25 S / ER 25 MS	12.00 - 12.50	21	4	11.80X1.50
SEALING DISC ER 25 12.50 - 13.00	K10152151204127	ER 25 S / ER 25 MS	12.50 - 13.00	21	4	12.30X1.50
SEALING DISC ER 25 13.00 - 13.50	K10152151305127	ER 25 S / ER 25 MS	13.00 - 13.50	21	4	12.80X1.50
SEALING DISC ER 25 13.50 - 14.00	K10152151205127	ER 25 S / ER 25 MS	13.50 - 14.00	21	4	13.30X1.50
SEALING DISC ER 25 14.00 - 14.50	K10152151206127	ER 25 S / ER 25 MS	14.00 - 14.50	21	4	13.80X1.50
SEALING DISC ER 25 14.50 - 15.00	K10152151207127	ER 25 S / ER 25 MS	14.50 - 15.00	21	4	14.30X1.50
SEALING DISC ER 25 15.00 - 15.50	K10152151208127	ER 25 S / ER 25 MS	15.00 - 15.50	21	4	14.80X1.50
SEALING DISC ER 25 15.50 - 16.00	K10152151209127	ER 25 S / ER 25 MS	15.50 - 16.00	21	4	15.30X1.50

Note: All Dimensions are in mm

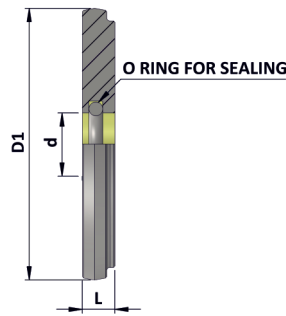
Sealing Disc ER 32

Item Name	Item Code	Suitable Nut	d	D1	L	'O' Ring Size
SEALING DISC ER 32 3.00 - 3.50	K10152152185127	ER 32 S	3.00 - 3.50	27	4	2.80X1.50
SEALING DISC ER 32 3.50 - 4.00	K10152152186127	ER 32 S	3.50 - 4.00	27	4	3.30X1.50
SEALING DISC ER 32 4.00 - 4.50	K10152152187127	ER 32 S	4.00 - 4.50	27	4	3.80X1.50
SEALING DISC ER 32 4.50 - 5.00	K10152152188127	ER 32 S	4.50 - 5.00	27	4	4.30X1.50
SEALING DISC ER 32 5.00 - 5.50	K10152152189127	ER 32 S	5.00 - 5.50	27	4	4.80X1.50
SEALING DISC ER 32 5.50 - 6.00	K10152152190127	ER 32 S	5.50 - 6.00	27	4	5.30X1.50
SEALING DISC ER 32 6.00 - 6.50	K10152152191127	ER 32 S	6.00 - 6.50	27	4	5.80x1.50
SEALING DISC ER 32 6.50 - 7.00	K10152152192127	ER 32 S	6.50 - 7.00	27	4	6.30x1.50
SEALING DISC ER 32 7.00 - 7.50	K10152152193127	ER 32 S	7.00 - 7.50	27	4	6.80x1.50
SEALING DISC ER 32 7.50 - 8.00	K10152152194127	ER 32 S	7.50 - 8.00	27	4	7.30X1.50
SEALING DISC ER 32 8.00 - 8.50	K10152152195127	ER 32 S	8.00 - 8.50	27	4	7.80X1.50
SEALING DISC ER 32 8.50 - 9.00	K10152152196127	ER 32 S	8.50 - 9.00	27	4	8.30X1.50
SEALING DISC ER 32 9.00 - 9.50	K10152152197127	ER 32 S	9.00 - 9.50	27	4	8.80X1.50
SEALING DISC ER 32 9.50 - 10.00	K10152152198127	ER 32 S	9.50 - 10.00	27	4	9.30X1.50
SEALING DISC ER 32 10.00 - 10.50	K10152152199127	ER 32 S	10.00 - 10.50	27	4	9.80X1.50
SEALING DISC ER 32 10.50 - 11.00	K10152152200127	ER 32 S	10.50 - 11.00	27	4	10.30X1.50
SEALING DISC ER 32 11.00 - 11.50	K10152152201127	ER 32 S	11.00 - 11.50	27	4	10.80X1.50
SEALING DISC ER 32 11.50 - 12.00	K1015215220212	ER 32 S	11.50 - 12.00	27	4	11.30X1.50
SEALING DISC ER 32 12.00 - 12.50	K10152152203127	ER 32 S	12.00 - 12.50	27	4	11.80X1.50
SEALING DISC ER 32 12.50 - 13.00	K10152152204127	ER 32 S	12.50 - 13.00	27	4	12.30X1.50
SEALING DISC ER 32 13.00 - 13.50	K10152152305127	ER 32 S	13.00 - 13.50	27	4	12.80X1.50
SEALING DISC ER 32 13.50 - 14.00	K10152152205127	ER 32 S	13.50 - 14.00	27	4	13.30X1.50
SEALING DISC ER 32 14.00 - 14.50	K10152152206127	ER 32 S	14.00 - 14.50	27	4	13.80X1.50
SEALING DISC ER 32 14.50 - 15.00	K10152152207127	ER 32 S	14.50 - 15.00	27	4	14.30X1.50
SEALING DISC ER 32 15.00 - 15.50	K10152152208127	ER 32 S	15.00 - 15.50	27	4	14.80X1.50
SEALING DISC ER 32 15.50 - 16.00	K10152152209127	ER 32 S	15.50 - 16.00	27	4	15.30X1.50
SEALING DISC ER 32 16.00 - 16.50	K10152152210127	ER 32 S	16.00 - 16.50	27	4	15.80X1.50
SEALING DISC ER 32 16.50 - 17.00	K10152152211127	ER 32 S	16.50 - 17.00	27	4	16.30X1.50
SEALING DISC ER 32 17.00 - 17.50	K10152152212127	ER 32 S	17.00 - 17.50	27	4	16.80X1.50
SEALING DISC ER 32 17.50 - 18.00	K10152152213127	ER 32 S	17.50 - 18.00	27	4	17.30X1.50
SEALING DISC ER 32 18.00 - 18.50	K10152152214127	ER 32 S	18.00 - 18.50	27	4	17.80X1.50
SEALING DISC ER 32 18.50 - 19.00	K10152152215127	ER 32 S	18.50 - 19.00	27	4	18.30X1.50
SEALING DISC ER 32 19.00 - 19.50	K10152152216127	ER 32 S	19.00 - 19.50	27	4	18.80X1.50
SEALING DISC ER 32 19.50 - 20.00	K10152152217127	ER 32 S	19.50 - 20.00	27	4	19.30X1.50

Note: All Dimensions are in mm

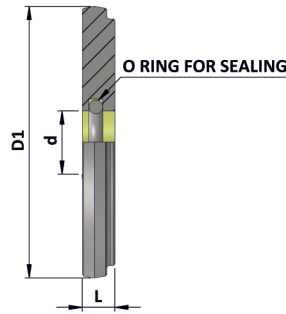
Sealing Disc ER 40

Item Name	Item Code	Suitable Nut	d	D1	L	'O' Ring Size
SEALING DISC ER 40 3.00 - 3.50	K10152153185127	ER 40 S	3.00 - 3.50	33	4	2.80X1.50
SEALING DISC ER 40 3.50 - 4.00	K10152153186127	ER 40 S	3.50 - 4.00	33	4	3.30X1.50
SEALING DISC ER 40 4.00 - 4.50	K10152153187127	ER 40 S	4.00 - 4.50	33	4	3.80X1.50
SEALING DISC ER 40 4.50 - 5.00	K10152153188127	ER 40 S	4.50 - 5.00	33	4	4.30X1.50
SEALING DISC ER 40 5.00 - 5.50	K10152153189127	ER 40 S	5.00 - 5.50	33	4	4.80X1.50
SEALING DISC ER 40 5.50 - 6.00	K10152153190127	ER 40 S	5.50 - 6.00	33	4	5.30X1.50
SEALING DISC ER 40 6.00 - 6.50	K10152153191127	ER 40 S	6.00 - 6.50	33	4	5.80X1.50
SEALING DISC ER 40 6.50 - 7.00	K10152153192127	ER 40 S	6.50 - 7.00	33	4	6.30X1.50
SEALING DISC ER 40 7.00 - 7.50	K10152153193127	ER 40 S	7.00 - 7.50	33	4	6.80X1.50
SEALING DISC ER 40 7.50 - 8.00	K10152153194127	ER 40 S	7.50 - 8.00	33	4	7.30X1.50
SEALING DISC ER 40 8.00 - 8.50	K10152153195127	ER 40 S	8.00 - 8.50	33	4	7.80X1.50
SEALING DISC ER 40 8.50 - 9.00	K10152153196127	ER 40 S	8.50 - 9.00	33	4	8.30X1.50
SEALING DISC ER 40 9.00 - 9.50	K10152153197127	ER 40 S	9.00 - 9.50	33	4	8.80X1.50
SEALING DISC ER 40 9.50 - 10.00	K10152153198127	ER 40 S	9.50 - 10.00	33	4	9.30X1.50
SEALING DISC ER 40 10.00 - 10.50	K10152153199127	ER 40 S	10.00 - 10.50	33	4	9.80X1.50
SEALING DISC ER 40 10.50 - 11.00	K10152153200127	ER 40 S	10.50 - 11.00	33	4	10.30X1.50
SEALING DISC ER 40 11.00 - 11.50	K10152153201127	ER 40 S	11.00 - 11.50	33	4	10.80X1.50
SEALING DISC ER 40 11.50 - 12.00	K10152153202127	ER 40 S	11.50 - 12.00	33	4	11.30X1.50
SEALING DISC ER 40 12.00 - 12.50	K10152153203127	ER 40 S	12.00 - 12.50	33	4	11.80X1.50
SEALING DISC ER 40 12.50 - 13.00	K10152153204127	ER 40 S	12.50 - 13.00	33	4	12.30X1.50
SEALING DISC ER 40 13.00 - 13.50	K10152153305127	ER 40 S	13.00 - 13.50	33	4	12.80X1.50
SEALING DISC ER 40 13.50 - 14.00	K10152153205127	ER 40 S	13.50 - 14.00	33	4	13.30X1.50
SEALING DISC ER 40 14.00 - 14.50	K10152153206127	ER 40 S	14.00 - 14.50	33	4	13.80X1.50
SEALING DISC ER 40 14.50 - 15.00	K10152153207127	ER 40 S	14.50 - 15.00	33	4	14.30X1.50
SEALING DISC ER 40 15.00 - 15.50	K10152153208127	ER 40 S	15.00 - 15.50	33	4	14.80X1.50
SEALING DISC ER 40 15.50 - 16.00	K10152153209127	ER 40 S	15.50 - 16.00	33	4	15.30X1.50
SEALING DISC ER 40 16.00 - 16.50	K10152153210127	ER 40 S	16.00 - 16.50	33	4	15.80X1.50
SEALING DISC ER 40 16.50 - 17.00	K10152153211127	ER 40 S	16.50 - 17.00	33	4	16.30X1.50
SEALING DISC ER 40 17.00 - 17.50	K10152153212127	ER 40 S	17.00 - 17.50	33	4	16.80X1.50
SEALING DISC ER 40 17.50 - 18.00	K10152153213127	ER 40 S	17.50 - 18.00	33	4	17.30X1.50
SEALING DISC ER 40 18.00 - 18.50	K10152153214127	ER 40 S	18.00 - 18.50	33	4	17.80X1.50
SEALING DISC ER 40 18.50 - 19.00	K10152153215127	ER 40 S	18.50 - 19.00	33	4	18.30X1.50
SEALING DISC ER 40 19.00 - 19.50	K10152153216127	ER 40 S	19.00 - 19.50	33	4	18.80X1.50
SEALING DISC ER 40 19.50 - 20.00	K10152153217127	ER 40 S	19.50 - 20.00	33	4	19.30X1.50
SEALING DISC ER 40 20.00 - 20.50	K10152153218127	ER 40 S	20.00 - 20.50	33	4	19.80X1.50

Note: All Dimensions are in mm

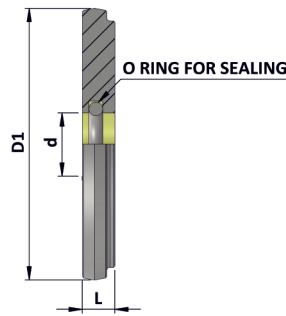

Sealing Disc ER 40

Item Name	Item Code	Suitable Nut	d	D1	L	'O' Ring Size
SEALING DISC ER 40 20.50 - 21.00	K10152153219127	ER 40 S	20.50 - 21.00	33	4	20.30X1.50
SEALING DISC ER 40 21.00 - 21.50	K10152153220127	ER 40 S	21.00 - 21.50	33	4	20.80X1.50
SEALING DISC ER 40 21.50 - 22.00	K10152153221127	ER 40 S	21.50 - 22.00	33	4	21.30X1.50
SEALING DISC ER 40 22.00 - 22.50	K10152153222127	ER 40 S	22.00 - 22.50	33	4	21.80X1.50
SEALING DISC ER 40 22.50 - 23.00	K10152153223127	ER 40 S	22.50 - 23.00	33	4	22.30X1.50
SEALING DISC ER 40 23.00 - 23.50	K10152153224127	ER 40 S	23.00 - 23.50	33	4	22.80X1.50
SEALING DISC ER 40 23.50 - 24.00	K10152153225127	ER 40 S	23.50 - 24.00	33	4	23.30X1.50
SEALING DISC ER 40 24.00 - 24.50	K10152153226127	ER 40 S	24.00 - 24.50	33	4	23.80X1.50
SEALING DISC ER 40 24.50 - 25.00	K10152153227127	ER 40 S	24.50 - 25.00	33	4	24.30X1.50
SEALING DISC ER 40 25.00 - 25.50	K10152153228127	ER 40 S	25.00 - 25.50	33	4	24.80X1.50
SEALING DISC ER 40 25.50 - 26.00	K10152153229127	ER 40 S	25.50 - 26.00	33	4	25.30X1.50

Sealing Disc ER 50

Item Name	Item Code	Suitable Nut	d	D1	L	'O' Ring Size
SEALING DISC ER 50 6.00 - 6.50	K10152154191127	ER 50 S	6.00 - 6.50	43.5	4.5	5.80X1.50
SEALING DISC ER 50 8.00 - 8.50	K10152154195127	ER 50 S	8.00 - 8.50	43.5	4.5	7.80X1.50
SEALING DISC ER 50 10.00 - 10.50	K10152154199127	ER 50 S	10.00 - 10.50	43.5	4.5	9.80X1.50
SEALING DISC ER 50 12.00 - 12.50	K10152154203127	ER 50 S	12.00 - 12.50	43.5	4.5	11.80X1.50
SEALING DISC ER 50 14.00 - 14.50	K10152154206127	ER 50 S	14.00 - 14.50	43.5	4.5	13.80X1.50
SEALING DISC ER 50 16.00 - 16.50	K10152154210127	ER 50 S	16.00 - 16.50	43.5	4.5	15.80X1.50
SEALING DISC ER 50 18.00 - 18.50	K10152154214127	ER 50 S	18.00 - 18.50	43.5	4.5	17.80X1.50
SEALING DISC ER 50 22.00 - 22.50	K10152154222127	ER 50 S	22.00 - 22.50	43.5	4.5	21.80X1.50
SEALING DISC ER 50 24.00 - 24.50	K10152154226127	ER 50 S	24.00 - 24.50	43.5	4.5	23.80X1.50
SEALING DISC ER 50 25.00 - 25.50	K10152154228127	ER 50 S	25.00 - 25.50	43.5	4.5	24.80X1.50
SEALING DISC ER 50 26.00 - 26.50	K10152154503127	ER 50 S	26.00 - 26.50	43.5	4.5	25.80X1.50
SEALING DISC ER 50 28.00 - 28.50	K10152154521127	ER 50 S	28.00 - 28.50	43.5	4.5	27.80X1.50
SEALING DISC ER 50 30.00 - 30.50	K10152154497127	ER 50 S	30.00 - 30.50	43.5	4.5	29.80X1.50
SEALING DISC ER 50 30.50 - 31.00	K10152154495127	ER 50 S	30.50 - 31.00	43.5	4.5	30.30x1.50
SEALING DISC ER 50 31.00 - 31.50	K10152154502127	ER 50 S	31.00 - 31.50	43.5	4.5	30.80X1.50
SEALING DISC ER 50 31.50 - 32.00	K10152154496127	ER 50 S	31.50 - 32.00	43.5	4.5	31.30X1.50
SEALING DISC ER 50 32.00 - 32.50	K10152154520127	ER 50 S	32.00 - 32.50	43.5	4.5	31.80X1.50

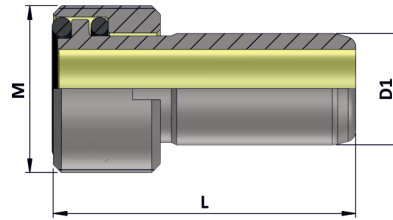
Note: All Dimensions are in mm



Coolant Tube For HSK-A (DIN 69893-1) Holder

Item Name	Item Code	HSK-A	D1	M	L
HSK-A 50 COOLANT TUBE	K10166232301127	50	10	M16X1	33
HSK-A 63 COOLANT TUBE	K10167232301127	63	12	M18X1	34
HSK-A 100 COOLANT TUBE	K10168232301127	100	16	M24X1.5	44

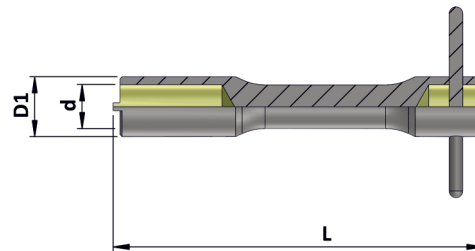

Spanner For HSK-A (DIN 69893-1) Coolant Tube

Item Name	Item Code	HSK-A	d	D1	L
HSK-A 50 COOLANT TUBE SPANNER	K10166233301127	50	10.5	14.5	90
HSK-A 63 COOLANT TUBE SPANNER	K10167233301127	63	12.2	16.5	136
HSK-A 100 COOLANT TUBE SPANNER	K10168233301127	100	16.2	22	136

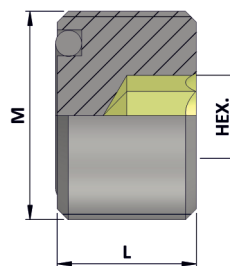

Sealing Plug For HSK-A

Item Name	Item Code	M	L	Hex
HSK-A 50 SEALING PLUG	K10166234301127	M16 X 1	10	5
HSK-A 63 SEALING PLUG	K10167234301127	M18 X 1	12	6
HSK-A 100 SEALING PLUG	K10168234301127	M24 X 1.5	16	10

Note: All Dimensions are in mm

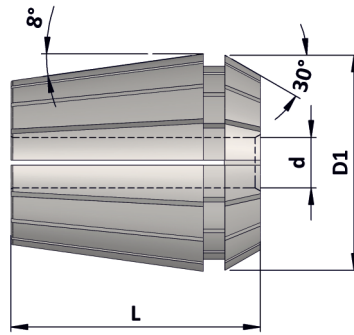

Collet ER (DIN6499) Class - 1

Item Name	Clamping Range (d)	Collet Collapse Range	D1	L	Run Out
Collet ER 11 Class-1	1 - 7	0.5 mm.	11.5	18	0.010 mm.
Collet ER 16 Class-1	1 - 10	1.0 mm.	17	27.5	0.010 mm.
Collet ER 20 Class-1	1 - 13	1.0 mm.	21	31.50	0.010 mm.
Collet ER 25 Class-1	1 - 16	1.0 mm.	26	34	0.010 mm.
Collet ER 32 Class-1	2 - 20	1.0 mm.	33	40	0.010 mm.
Collet ER 40 Class-1	3 - 26	1.0 mm.	41	46	0.010 mm.
Collet ER 50 Class-1	10 - 34	2.0 mm.	52	60	0.010 mm.

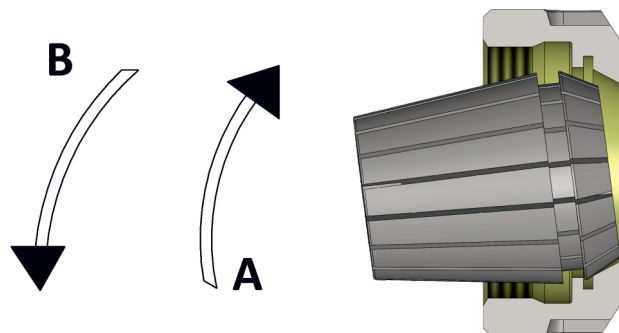

ER Collet & Nut Operating Method :

- The Collet must always be inserted into the nut before setting the tool into the collet.
- The collet is fitted inside the nut by applying slight pressure **A**.
- It is removed by applying Pressure **B** to the collet.
- Never tighten the chuck without a correct size tool shank being present in the collet.



Collet Set ER (DIN 6499)

Item Name	Item Code	Clamping Range	PCS / SET
COLLET SET ER 11 (1 - 7 MM) 7 PIECES CLASS I	K10264148493207	1 - 7	7
COLLET SET ER 16 (1-10 MM) 10 PCS WITH BOX CLASS I	K10264149484207	1 - 10	10
COLLET SET ER 20 (2-13 MM)12 PCS WITH BOX CLASS I	K10264150535207	2 - 13	12
COLLET SET ER 25 (2- 16 MM) 15PCS WITH BOX CLASS I	K10264151514207	2 - 16	15
COLLET SET ER 32 (3-20 MM) 18 PCS WITH BOX CLASS I	K10264152485207	3 - 20	18
COLLET SET ER 40 (3-26 MM) 24 PCS WITH BOX CLASS I	K10264153494207	3 - 26	24

Note: All Dimensions are in mm

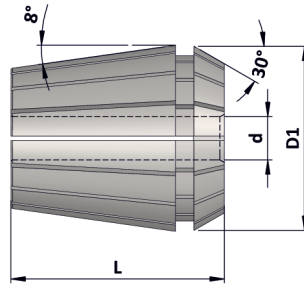
Collet ER 11 (Class-1)

Item Name	Item Code	Clamping Range (d)	D1	L
COLLET ER11 DIA 1.0 - 0.5 - CLASS I	K10154329301207	1.0 - 0.50	11.5	18
COLLET ER11 DIA 2.0 - 1.5 - CLASS I	K10154331301207	2.0 - 1.5	11.5	18
COLLET ER11 DIA 3.0 - 2.5 - CLASS I	K10154333301207	3.0 - 2.5	11.5	18
COLLET ER11 DIA 4.0 - 3.5 - CLASS I	K10154335301207	4.0 - 3.5	11.5	18
COLLET ER11 DIA 5.0 - 4.5 - CLASS I	K10154337301207	5.0 - 4.5	11.5	18
COLLET ER11 DIA 6.0 - 5.5 - CLASS I	K10154339301207	6.0 - 5.5	11.5	18
COLLET ER11 DIA 7.0 - 6.5 - CLASS I	K10154343301207	7.0 - 6.5	11.5	18

Collet ER 16 (Class-1)

COLLET ER16 DIA 1.0 - 0.5 - CLASS I	K10155291301207	1.0 - 0.50	17	27.5
COLLET ER16 DIA 2.0 - 1.0 - CLASS I	K10155292301207	2.0 - 1.0	17	27.5
COLLET ER16 DIA 3.0 - 2.0 - CLASS I	K10155293301207	3.0 - 2.0	17	27.5
COLLET ER16 DIA 4.0 - 3.0 - CLASS I	K10155294301207	4.0 - 3.0	17	27.5
COLLET ER16 DIA 5.0 - 4.0 - CLASS I	K10155295301207	5.0 - 4.0	17	27.5
COLLET ER16 DIA 6.0 - 5.0 - CLASS I	K10155296301207	6.0 - 5.0	17	27.5
COLLET ER16 DIA 7.0 - 6.0 - CLASS I	K10155297301207	7.0 - 6.0	17	27.5
COLLET ER16 DIA 8.0 - 7.0 - CLASS I	K10155298301207	8.0 - 7.0	17	27.5
COLLET ER16 DIA 9.0 - 8.0 - CLASS I	K10155299301207	9.0 - 8.0	17	27.5
COLLET ER16 DIA 10.0 - 9.0 - CLASS I	K10155300301207	10.0 - 9.0	17	27.5

Collet ER 20 (Class-1)

COLLET ER20 DIA 1.0 - 0.50 - CLASS I	K10156329301207	1 - 0.50	21	31.5
COLLET ER20 DIA 2 - 1 - CLASS I	K10156292301207	2 - 1	21	31.5
COLLET ER20 DIA 3 - 2 - CLASS I	K10156293301207	3 - 2	21	31.5
COLLET ER20 DIA 4 - 3 - CLASS I	K10156294301207	4 - 3	21	31.5
COLLET ER20 DIA 5 - 4 - CLASS I	K10156295301207	5 - 4	21	31.5
COLLET ER20 DIA 6 - 5 - CLASS I	K10156296301207	6 - 5	21	31.5
COLLET ER20 DIA 7 - 6 - CLASS I	K10156297301207	7 - 6	21	31.5
COLLET ER20 DIA 8 - 7 - CLASS I	K10156298301207	8 - 7	21	31.5
COLLET ER20 DIA 9 - 8 - CLASS I	K10156299301207	9 - 8	21	31.5
COLLET ER20 DIA 10 - 9 - CLASS I	K10156300301207	10 - 9	21	31.5
COLLET ER20 DIA 11 - 10 - CLASS I	K10156301301207	11 - 10	21	31.5
COLLET ER20 DIA 12 - 11 - CLASS I	K10156302301207	12 - 11	21	31.5
COLLET ER20 DIA 13 - 12 - CLASS I	K10156303301207	13 - 12	21	31.5

Note: All Dimensions are in mm

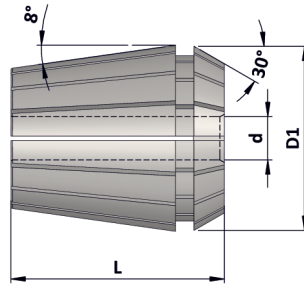
Collet ER 25 (Class-1)

Item Name	Item Code	Clamping Range (d)	D1	L
COLLET ER25 DIA 1.0 - 0.50 - CLASS I	K10157329301207	1.0 - 0.50	26	34
COLLET ER25 DIA 2 - 1 - CLASS I	K10157292301207	2 - 1	26	34
COLLET ER25 DIA 3 - 2 - CLASS I	K10157293301207	3 - 2	26	34
COLLET ER25 DIA 4 - 3 - CLASS I	K10157294301207	4 - 3	26	34
COLLET ER25 DIA 5 - 4 - CLASS I	K10157295301207	5 - 4	26	34
COLLET ER25 DIA 6 - 5 - CLASS I	K10157296301207	6 - 5	26	34
COLLET ER25 DIA 7 - 6 - CLASS I	K10157297301207	7 - 6	26	34
COLLET ER25 DIA 8 - 7 - CLASS I	K10157298301207	8 - 7	26	34
COLLET ER25 DIA 9 - 8 - CLASS I	K10157299301207	9 - 8	26	34
COLLET ER25 DIA 10 - 9 - CLASS I	K10157300301207	10 - 9	26	34
COLLET ER25 DIA 11 - 10 - CLASS I	K10157301301207	11 - 10	26	34
COLLET ER25 DIA 12 - 11 - CLASS I	K10157302301207	12 - 11	26	34
COLLET ER25 DIA 13 - 12 - CLASS I	K10157303301207	13 - 12	26	34
COLLET ER25 DIA 14 - 13 - CLASS I	K10157304301207	14 - 13	26	34
COLLET ER25 DIA 15 - 14 - CLASS I	K10157305301207	15 - 14	26	34
COLLET ER25 DIA 16 - 15 - CLASS I	K10157306301207	16 - 15	26	34

Collet ER 32 (Class-1)

COLLET ER32 DIA 1.0 - 0.50 - CLASS I	K10158291301207	1.0 - 0.50	33	40
COLLET ER32 DIA 2 - 1 - CLASS I	K10158292301207	2 - 1	33	40
COLLET ER32 DIA 3 - 2 - CLASS I	K10158293301207	3 - 2	33	40
COLLET ER32 DIA 4 - 3 - CLASS I	K10158294301207	4 - 3	33	40
COLLET ER32 DIA 5 - 4 - CLASS I	K10158295301207	5 - 4	33	40
COLLET ER32 DIA 6 - 5 - CLASS I	K10158296301207	6 - 5	33	40
COLLET ER32 DIA 7 - 6 - CLASS I	K10158297301207	7 - 6	33	40
COLLET ER32 DIA 8 - 7 - CLASS I	K10158298301207	8 - 7	33	40
COLLET ER32 DIA 9 - 8 - CLASS I	K10158299301207	9 - 8	33	40
COLLET ER32 DIA 10 - 9 - CLASS I	K10158300301207	10 - 9	33	40
COLLET ER32 DIA 11 - 10 - CLASS I	K10158301301207	11 - 10	33	40
COLLET ER32 DIA 12 - 11 - CLASS I	K10158302301207	12 - 11	33	40
COLLET ER32 DIA 13 - 12 - CLASS I	K10158303301207	13 - 12	33	40
COLLET ER32 DIA 14 - 13 - CLASS I	K10158304301207	14 - 13	33	40
COLLET ER32 DIA 15 - 14 - CLASS I	K10158305301207	15 - 14	33	40
COLLET ER32 DIA 16 - 15 - CLASS I	K10158306301207	16 - 15	33	40
COLLET ER32 DIA 17 - 16 - CLASS I	K10158307301207	17 - 16	33	40
COLLET ER32 DIA 18 - 17 - CLASS I	K10158308301207	18 - 17	33	40
COLLET ER32 DIA 19 - 18 - CLASS I	K10158309301207	19 - 18	33	40
COLLET ER32 DIA 20 - 19 - CLASS I	K10158310301207	20 - 19	33	40

Note: All Dimensions are in mm

Collet ER 40 (Class-1)

Item Name	Item Code	Clamping Range (d)	D1	L
COLLET ER40 DIA 3 - 2 - CLASS I	K10159293301207	3 - 2	41	46
COLLET ER40 DIA 4 - 3 - CLASS I	K10159294301207	4 - 3	41	46
COLLET ER40 DIA 5 - 4 - CLASS I	K10159295301207	5 - 4	41	46
COLLET ER40 DIA 6 - 5 - CLASS I	K10159296301207	6 - 5	41	46
COLLET ER40 DIA 7 - 6 - CLASS I	K10159297301207	7 - 6	41	46
COLLET ER40 DIA 8 - 7 - CLASS I	K10159298301207	8 - 7	41	46
COLLET ER40 DIA 9 - 8 - CLASS I	K10159299301207	9 - 8	41	46
COLLET ER40 DIA 10 - 9 - CLASS I	K10159300301207	10 - 9	41	46
COLLET ER40 DIA 11 - 10 - CLASS I	K10159301301207	11 - 10	41	46
COLLET ER40 DIA 12 - 11 - CLASS I	K10159302301207	12 - 11	41	46
COLLET ER40 DIA 13 - 12 - CLASS I	K10159303301207	13 - 12	41	46
COLLET ER40 DIA 14 - 13 - CLASS I	K10159304301207	14 - 13	41	46
COLLET ER40 DIA 15 - 14 - CLASS I	K10159305301207	15 - 14	41	46
COLLET ER40 DIA 16 - 15 - CLASS I	K10159306301207	16 - 15	41	46
COLLET ER40 DIA 17 - 16 - CLASS I	K10159307301207	17 - 16	41	46
COLLET ER40 DIA 18 - 17 - CLASS I	K10159308301207	18 - 17	41	46
COLLET ER40 DIA 19 - 18 - CLASS I	K10159309301207	19 - 18	41	46
COLLET ER40 DIA 20 - 19 - CLASS I	K10159310301207	20 - 19	41	46
COLLET ER40 DIA 21 - 20 - CLASS I	K10159311301207	21 - 20	41	46
COLLET ER40 DIA 22 - 21 - CLASS I	K10159312301207	22 - 21	41	46
COLLET ER40 DIA 23 - 22 - CLASS I	K10159313301207	23 - 22	41	46
COLLET ER40 DIA 24 - 23 - CLASS I	K10159314301207	24 - 23	41	46
COLLET ER40 DIA 25 - 24 - CLASS I	K10159315301207	25 - 24	41	46
COLLET ER40 DIA 26 - 25 - CLASS I	K10159316301207	26 - 25	41	46

Collet ER 50 (Class-1)

COLLET ER50 DIA 4 - 3 - CLASS I	K10196495301207	4 - 3	52	60
COLLET ER50 DIA 6 - 5 - CLASS I	K10196494301207	6 - 5	52	60
COLLET ER50 DIA 10 - 9 - CLASS I	K10196493301207	10 - 9	52	60
COLLET ER50 DIA 12 - 10 - CLASS I	K10196317301207	12 - 10	52	60
COLLET ER50 DIA 14 - 12 - CLASS I	K10196318301207	14 - 12	52	60
COLLET ER50 DIA 16 - 14 - CLASS I	K10196319301207	16 - 14	52	60
COLLET ER50 DIA 18 - 16 - CLASS I	K10196320301207	18 - 16	52	60
COLLET ER50 DIA 20 - 18 - CLASS I	K10196321301207	20 - 18	52	60
COLLET ER50 DIA 22 - 20 - CLASS I	K10196322301207	22 - 20	52	60
COLLET ER50 DIA 24 - 22 - CLASS I	K10196323301207	24 - 22	52	60
COLLET ER50 DIA 26 - 24 - CLASS I	K10196324301207	26 - 24	52	60
COLLET ER50 DIA 28 - 26 - CLASS I	K10196325301207	28 - 26	52	60
COLLET ER50 DIA 30 - 28 - CLASS I	K10196326301207	30 - 28	52	60
COLLET ER50 DIA 32 - 30 - CLASS I	K10196327301207	32 - 30	52	60
COLLET ER50 DIA 34 - 32 - CLASS I	K10196328301207	34 - 32	52	60

Note: All Dimensions are in mm

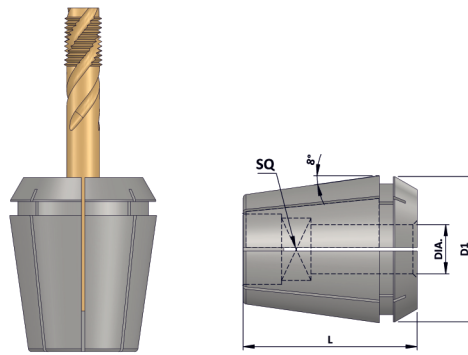

Tap Collet ER 16 G

Item Name	Item Code	Dia	Square	D1	L
TAP COLLET ER 16G 3.5 X 2.7	K10255479449127	3.50	2.70	17	27.5
TAP COLLET ER 16G 4.0 X 3.0	K10255479450127	4.00	3.00	17	27.5
TAP COLLET ER 16G 4.0 X 3.15	K10255479565127	4.00	3.15	17	27.5
TAP COLLET ER 16G 4.5 X 3.4	K10255479451127	4.50	3.40	17	27.5
TAP COLLET ER 16G 5.0 X 4.0	K10255479452127	5.00	4.00	17	27.5
TAP COLLET ER 16G 5.5 X 4.3	K10255479557127	5.50	4.30	17	27.5
TAP COLLET ER 16G 6.0 X 4.9	K10255479453127	6.00	4.90	17	27.5
TAP COLLET ER 16G 6.3 X 5.0	K10255479454127	6.30	5.00	17	27.5
TAP COLLET ER 16G 7.0 X 5.5	K10255479455127	7.00	5.50	17	27.5
TAP COLLET ER 16G 7.1 X 5.6	K10255479570127	7.10	5.60	17	27.5
TAP COLLET ER 16G 8.0 X 6.2	K10255479456127	8.00	6.20	17	27.5
TAP COLLET ER 16G 8.0 X 6.3	K10255479456225	8.00	6.30	17	27.5
TAP COLLET ER 16G 9.0 X 7.0	K10255479457127	9.00	7.00	17	27.5
TAP COLLET ER 16G 9.0 X 7.1	K10255479474127	9.00	7.10	17	27.5
TAP COLLET ER 16G 10.0 X 8.0	K10255479458127	10.00	8.00	17	27.5

Tap Collet ER 20 G

TAP COLLET ER 20G 3.5 X 2.7	K10255480449127	3.50	2.70	21	31.5
TAP COLLET ER 20G 4.0 X 3.0	K10255480450127	4.00	3.00	21	31.5
TAP COLLET ER 20G 4.0 X 3.15	K10255480565127	4.00	3.15	21	31.5
TAP COLLET ER 20G 4.5 X 3.4	K10255480451127	4.50	3.40	21	31.5
TAP COLLET ER 20G 5.0 X 4.0	K10255480452127	5.00	4.00	21	31.5
TAP COLLET ER 20G 5.5 X 4.3	K10255480557127	5.50	4.30	21	31.5
TAP COLLET ER 20G 6.0 X 4.9	K10255480453127	6.00	4.90	21	31.5
TAP COLLET ER 20G 6.3 X 5.0	K10255480454127	6.30	5.00	21	31.5
TAP COLLET ER 20G 7.0 X 5.5	K10255480455127	7.00	5.50	21	31.5
TAP COLLET ER 20G 7.1 X 5.6	K10255480570127	7.10	5.60	21	31.5
TAP COLLET ER 20G 8.0 X 6.2	K10255480456127	8.00	6.20	21	31.5
TAP COLLET ER 20G 8.0 X 6.3	K10255480456225	8.00	6.30	21	31.5
TAP COLLET ER 20G 9.0 X 7.0	K10255480457127	9.00	7.00	21	31.5
TAP COLLET ER 20G 9.0 X 7.1	K10255480474127	9.00	7.10	21	31.5
TAP COLLET ER 20G 10.0 X 8.0	K10255480458127	10.00	8.00	21	31.5
TAP COLLET ER 20G 11.0 X 9.0	K10255480469127	11.00	9.00	21	31.5
TAP COLLET ER 20G 11.2 X 9.0	K10255480459127	11.20	9.00	21	31.5
TAP COLLET ER 20G 12.0 X 9.0	K10255480460127	12.00	9.00	21	31.5

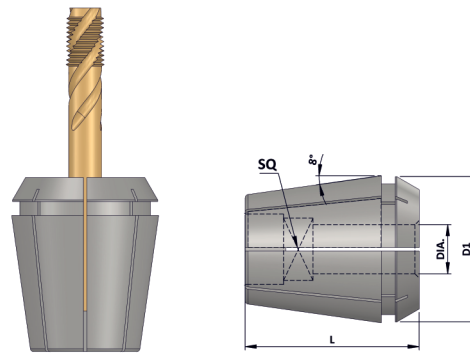
Note: All Dimensions are in mm

Tap Collet ER 25 G

Item Name	Item Code	Dia	Square	D1	L
TAP COLLET ER 25G 3.5 X 2.7	K10255151449127	3.50	2.70	26	34
TAP COLLET ER 25G 4.0 X 3.0	K10255481450127	4.00	3.00	26	34
TAP COLLET ER 25G 4.0 X 3.15	K10255481565127	4.00	3.15	26	34
TAP COLLET ER 25G 4.5 X 3.4	K10255481451127	4.50	3.40	26	34
TAP COLLET ER 25G 5.0 X 4.0	K10255481452127	5.00	4.00	26	34
TAP COLLET ER 25G 5.5 X 4.3	K10255481557127	5.50	4.30	26	34
TAP COLLET ER 25G 6.0 X 4.9	K10255481453127	6.00	4.90	26	34
TAP COLLET ER 25G 6.3 X 5.0	K10255481454127	6.30	5.00	26	34
TAP COLLET ER 25G 7.0 X 5.5	K10255481455127	7.00	5.50	26	34
TAP COLLET ER 25G 7.1 X 5.6	K10255481570127	7.10	5.60	26	34
TAP COLLET ER 25G 8.0 X 6.2	K10255481456127	8.00	6.20	26	34
TAP COLLET ER 25G 8.0 X 6.3	K10255481195127	8.00	6.30	26	34
TAP COLLET ER 25G 9.0 X 7.0	K10255481457127	9.00	7.00	26	34
TAP COLLET ER 25G 9.0 X 7.1	K10255481474127	9.00	7.10	26	34
TAP COLLET ER 25G 10.0 X 8.0	K10255481458127	10.00	8.00	26	34
TAP COLLET ER 25G 11.0 X 9.0	K10255481469127	11.00	9.00	26	34
TAP COLLET ER 25G 11.2 X 9.0	K10255481459127	11.20	9.00	26	34
TAP COLLET ER 25G 12.0 X 9.0	K10255481460127	12.00	9.00	26	34
TAP COLLET ER 25G 12.5 X 10.0	K10255481461127	12.50	10.00	26	34
TAP COLLET ER 25G 14.0 X 11.0	K10255481462127	14.00	11.00	26	34
TAP COLLET ER 25G 14.0 X 11.2	K10255481463127	14.00	11.20	26	34
TAP COLLET ER 25G 16.0 X 12.0	K10255481470127	16.00	12.00	26	34

Tap Collet ER 32 G

TAP COLLET ER 32G 3.5 X 2.7	K10255482449127	3.50	2.70	33	40
TAP COLLET ER 32G 4.0 X 3.0	K10102173256127	4.00	3.00	33	40
TAP COLLET ER 32G 4.0 X 3.15	K10255482565127	4.00	3.15	33	40
TAP COLLET ER 32G 4.5 X 3.4	K10255482451127	4.50	3.40	33	40
TAP COLLET ER 32G 5.0 X 4.0	K10255482452127	5.00	4.00	33	40
TAP COLLET ER 32G 5.5 X 4.3	K10255482557127	5.50	4.30	33	40
TAP COLLET ER 32G 6.0 X 4.9	K10255482453127	6.00	4.90	33	40
TAP COLLET ER 32G 6.3 X 5.0	K10255482454127	6.30	5.00	33	40
TAP COLLET ER 32G 7.0 X 5.5	K10255482455127	7.00	5.50	33	40
TAP COLLET ER 32G 7.1 X 5.6	K10255482570127	7.10	5.60	33	40
TAP COLLET ER 32G 8.0 X 6.2	K10255482456127	8.00	6.20	33	40

Note: All Dimensions are in mm

Continued...

Tap Collet ER 32 G

Item Name	Item Code	Dia	Square	D1	L
TAP COLLET ER 32G 8.0 X 6.3	K10255482564127	8.00	6.30	33	40
TAP COLLET ER 32G 9.0 X 7.0	K10255482457127	9.00	7.00	33	40
TAP COLLET ER 32G 9.0 X 7.1	K10255482474127	9.00	7.10	33	40
TAP COLLET ER 32G 10.0 X 8.0	K10255482458127	10.00	8.00	33	40
TAP COLLET ER 32G 11.0 X 9.0	K10255482469127	11.00	9.00	33	40
TAP COLLET ER 32G 11.2 X 9.0	K10255482459127	11.20	9.00	33	40
TAP COLLET ER 32G 12.0 X 9.0	K10255482460127	12.00	9.00	33	40
TAP COLLET ER 32G 12.5 X 10.0	K10255482461127	12.50	10.00	33	40
TAP COLLET ER 32G 14.0 X 11.0	K10255482462127	14.00	11.00	33	40
TAP COLLET ER 32G 14.0 X 11.2	K10255482463127	14.00	11.20	33	40
TAP COLLET ER 32G 16.0 X 12.0	K10255482470127	16.00	12.00	33	40
TAP COLLET ER 32G 16.0 X 12.5	K10255482464127	16.00	12.50	33	40
TAP COLLET ER 32G 18.0 X 14.0	K10255152558127	18.00	14.00	33	40
TAP COLLET ER 32G 18.0 X 14.5	K10255482465127	18.00	14.50	33	40
TAP COLLET ER 32G 20.0 X 16.0	K10255482466127	20.00	16.00	33	40

Tap Collet ER 40 G

TAP COLLET ER 40G 3.5 X 2.7	K10255153449127	3.50	2.70	41	46
TAP COLLET ER 40G 4.0 X 3.0	K10255483450127	4.00	3.00	41	46
TAP COLLET ER 40G 4.5 X 3.4	K10255153451127	4.50	3.40	41	46
TAP COLLET ER 40G 6.0 X 4.9	K10255483453127	6.00	4.90	41	46
TAP COLLET ER 40G 6.3 X 5.0	K10255483454127	6.30	5.00	41	46
TAP COLLET ER 40G 7.0 X 5.5	K10255483455127	7.00	5.50	41	46
TAP COLLET ER 40G 7.1 X 5.6	K10255483570127	7.10	5.60	41	46
TAP COLLET ER 40G 8.0 X 6.2	K10255483456127	8.00	6.20	41	46
TAP COLLET ER 40G 8.0 X 6.3	K10255483456207	8.00	6.30	41	46
TAP COLLET ER 40G 9.0 X 7.0	K10255483457127	9.00	7.00	41	46
TAP COLLET ER 40G 9.0 X 7.1	K10255483474127	9.00	7.10	41	46
TAP COLLET ER 40G 10.0 X 8.0	K10255483458127	10.00	8.00	41	46
TAP COLLET ER 40G 11.0 X 9.0	K10255483469127	11.00	9.00	41	46
TAP COLLET ER 40G 11.2 X 9.0	K10255483459127	11.20	9.00	41	46
TAP COLLET ER 40G 12.0 X 9.0	K10255483460127	12.00	9.00	41	46
TAP COLLET ER 40G 12.5 X 10.0	K10255483461127	12.50	10.00	41	46
TAP COLLET ER 40G 14.0 X 11.0	K10255483462127	14.00	11.00	41	46
TAP COLLET ER 40G 14.0 X 11.2	K10255483463127	14.00	11.20	41	46
TAP COLLET ER 40G 16.0 X 12.0	K10255483470127	16.00	12.00	41	46
TAP COLLET ER 40G 16.0 X 12.5	K10255483464127	16.00	12.50	41	46
TAP COLLET ER 40G 18.0 X 14.0	K10255153558127	18.00	14.00	41	46
TAP COLLET ER 40G 18.0 X 14.5	K10255483465127	18.00	14.50	41	46
TAP COLLET ER 40G 20.0 X 16.0	K10255483466127	20.00	16.00	41	46
TAP COLLET ER 40G 22.0 X 18.0	K10255483467127	22.00	18.00	41	46
TAP COLLET ER 40G 22.4 X 18.0	K10255483575127	22.40	18.00	41	46
TAP COLLET ER 40G 25.0 X 20.0	K10255483468127	25.00	20.00	41	46

Note: All Dimensions are in mm

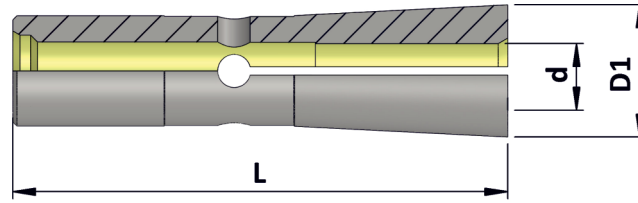

Collet DMC

(Concentricity within 0.005 mm)

Item Name	Item Code	d	D1	L
COLLET DMC06 02	K10108199301127	2	9.6	36
COLLET DMC06 03	K10108200301127	3	9.6	36
COLLET DMC06 04	K10108201301127	4	9.6	36
COLLET DMC06 05	K10108202301127	5	9.6	36
COLLET DMC06 06	K10108203301127	6	9.6	36
COLLET DMC08 03	K10109200301127	3	15	45
COLLET DMC08 04	K10109201301127	4	15	45
COLLET DMC08 06	K10109203301127	6	15	45
COLLET DMC08 08	K10109205301127	8	15	45
COLLET DMC10 04	K10110201301127	4	19.1	52
COLLET DMC10 06	K10110203301127	6	19.1	52
COLLET DMC10 08	K10110205301127	8	19.1	52
COLLET DMC10 10	K10110207301127	10	19.1	52

Note: All Dimensions are in mm

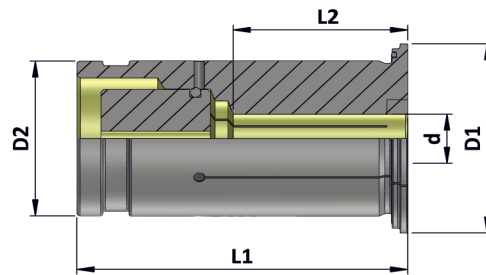

Reduction Sleeve (RS)

(Concentricity within 0.005 mm)

Item Name	Item Code	d	D1	D2	L1	L2
RS 12 X 3	K10310182301127	3	16.50	12	48	14
RS 12 X 4	K10310183301127	4	16.50	12	48	15
RS 12 X 5	K10310184301127	5	16.50	12	48	18
RS 12 X 6	K10310185301127	6	16.50	12	48	25
RS 12 X 8	K10310187301127	8	16.50	12	48	26
RS 20 X 3	K10106182301127	3	29	20	52.5	14
RS 20 X 4	K10106183301127	4	29	20	52.5	15
RS 20 X 5	K10106184301127	5	29	20	52.5	18
RS 20 X 6	K10106185301127	6	29	20	52.5	25
RS 20 X 7	K10106186301127	7	29	20	52.5	25
RS 20 X 8	K10106187301127	8	29	20	52.5	30
RS 20 X 9	K10106188301127	9	29	20	52.5	30
RS 20 X10	K10106189301127	10	29	20	52.5	33
RS 20 X11	K10106190301127	11	29	20	52.5	33
RS 20 X12	K10106191301127	12	29	20	52.5	34
RS 20 X13	K10106192301127	13	29	20	52.5	34
RS 20 X14	K10106193301127	14	29	20	52.5	34
RS 20 X15	K10106194301127	15	29	20	52.5	40
RS 20 X16	K10106195301127	16	29	20	52.5	40
RS 32 X 6	K10107185301127	6	39	32	63.5	25
RS 32 X 8	K10107187301127	8	39	32	63.5	25
RS 32 X10	K10107189301127	10	39	32	63.5	33
RS 32 X12	K10107191301127	12	39	32	63.5	34
RS 32 X14	K10107193301127	14	39	32	63.5	34
RS 32 X16	K10107195301127	16	39	32	63.5	40
RS 32 X18	K10107271301127	18	39	32	63.5	40
RS 32 X20	K10107196301127	20	39	32	63.5	40
RS 32 X25	K10107197301127	25	39	32	63.5	42

Note: All Dimensions are in mm

Quick Change Tap Collet
ER Type (Rigid)
(QCTC-ER)

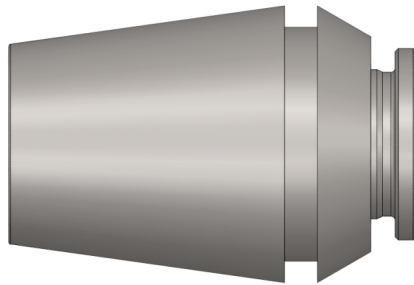

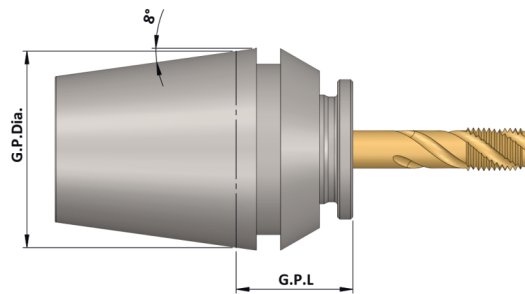

Technical Information

Item Name	G.P. Dia	G. P. L.	Tap Holding Range Dia. x Sq.		Tapping Range
			Min.	Max.	
QCTC -ER16	16.00	14.00	Ø3.15 x 2.50 SQ.	Ø6.30 x 5.00 SQ.	M3 TO M8
QCTC -ER20	20.00	15.50	Ø3.15 x 2.50 SQ.	Ø7.10 x 5.60 SQ.	M3 TO M10
QCTC -ER25	25.00	16.00	Ø3.15 x 2.50 SQ.	Ø10.00 x 8.00 SQ.	M3 TO M12
QCTC -ER32	32.00	20.00	Ø3.15 x 2.50 SQ.	Ø14.00 x 11.20 SQ.	M3 TO M20
QCTC -ER40	40.00	22.00	Ø3.15 x 2.50 SQ.	Ø18.00 x 14.50 SQ.	M3 TO M24

◆ Features :

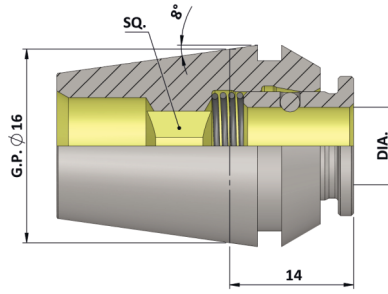
- This System is to be used along with “ER” Collect Chuck on CNC & spm’s for Rigid Tapping Operation.
- No Compression & No Expansion.
- Use External Coolant Supply.
- Rigid Clamping & Quick Replace of Tap.
- Tap Collet Selection According to the ER type & the Diameter & Square of the Tap.



QCTC ER 16

As per (ISO) (529 -1975) Standards

Item Name	Item Code	Dia	Square
QCTC ER 16 3.15 X 2.50	K11259304297	3.15	2.50
QCTC ER 16 3.55 X 2.80	K11259304298	3.55	2.80
QCTC ER 16 4.0 X 3.15	K11259304300	4.00	3.15
QCTC ER 16 4.50 X 3.55	K11259304299	4.50	3.55
QCTC ER 16 5.0 X 4.0	K11259304301	5.00	4.00
QCTC ER 16 5.60 X 4.50	K11259304302	5.60	4.50
QCTC ER 16 6.3 X 5.0	K11259304291	6.30	5.00

As per (DIN) Standards

QCTC ER 16 3.5 X 2.7	K11259304276	3.50	2.70
QCTC ER 16 4.0 X 3.0	K11259304277	4.00	3.00
QCTC ER 16 4.5 X 3.4	K11259304278	4.50	3.40
QCTC ER 16 6.0 X 4.9	K11259304279	6.00	4.90

As per (JIS) Standards

QCTC ER 16 4.0 X 3.0	K11259304277	4.00	3.00
QCTC ER 16 4.0 X 3.20	K11259304306	4.00	3.20
QCTC ER 16 5.0 X 4.0	K11259304301	5.00	4.00
QCTC ER 16 5.5 X 4.5	K11259238307	5.50	4.50
QCTC ER 16 6.0 X 4.50	K11259304308	6.00	4.50
QCTC ER 16 6.10 X 5.0	K11259304309	6.10	5.00
QCTC ER 16 6.20 X 5.0	K11259304310	6.20	5.00

Note: All Dimensions are in mm
For DIN Standard Numbers and more technical details please see page number 281 - 284

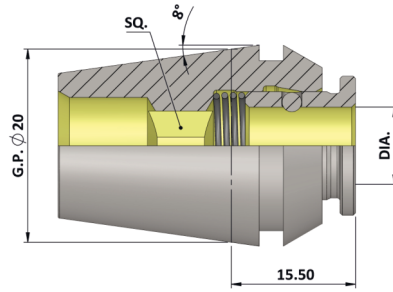

QCTC ER 20

As per (ISO) (529 -1975) Standards

Item Name	Item Code	Dia	Square
QCTC ER 20 3.15 X 2.50	K11259305297	3.15	2.50
QCTC ER 20 3.55 X 2.80	K11259305298	3.55	2.80
QCTC ER 20 4.0 X 3.15	K11259305300	4.00	3.15
QCTC ER 20 4.50 X 3.55	K11259305299	4.50	3.55
QCTC ER 20 5.0 X 4.0	K11259305301	5.00	4.00
QCTC ER 20 5.60 X 4.50	K11259305302	5.60	4.50
QCTC ER 20 6.3 X 5.0	K11259305291	6.30	5.00
QCTC ER 20 7.10 X 5.60	K11259305292	7.10	5.60

As per (DIN) Standards

QCTC ER 20 3.5 X 2.7	K11259305276	3.50	2.70
QCTC ER 20 4.0 X 3.0	K11259305277	4.00	3.00
QCTC ER 20 4.5 X 3.4	K11259305278	4.50	3.40
QCTC ER 20 6.0 X 4.9	K11259305279	6.00	4.90
QCTC ER 20 7.0 X 5.5	K11259305280	7.00	5.50

As per (JIS) Standards

QCTC ER 20 4.0 X 3.0	K11259305277	4.00	3.00
QCTC ER 20 4.0 X 3.20	K11259305306	4.00	3.20
QCTC ER 20 5.0 X 4.0	K11259305301	5.00	4.00
QCTC ER 20 5.50 X 4.50	K11259305307	5.50	4.50
QCTC ER 20 6.0 X 4.50	K11259305308	6.00	4.50
QCTC ER 20 6.10 X 5.0	K11259305309	6.10	5.00
QCTC ER 20 6.20 X 5.0	K11259305310	6.20	5.00
QCTC ER 20 7.0 X 5.5	K11259305280	7.00	5.50

Note: All Dimensions are in mm
For DIN Standard Numbers and more technical details please see page number 281 - 284

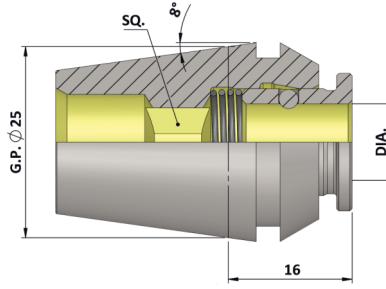

QCTC ER 25

As per (ISO) (529 -1975) Standards

Item Name	Item Code	Dia	Square
QCTC ER 25 3.15 X 2.50	K11259306297	3.15	2.50
QCTC ER 25 3.55 X 2.80	K11259306298	3.55	2.80
QCTC ER 25 4.0 X 3.15	K11259306300	4.00	3.15
QCTC ER 25 4.50 X 3.55	K11259306299	4.50	3.55
QCTC ER 25 5.0 X 4.0	K11259306301	5.00	4.00
QCTC ER 25 5.60 X 4.50	K11259306302	5.60	4.50
QCTC ER 25 6.3 X 5.0	K11259306291	6.30	5.00
QCTC ER 25 7.1 X 5.6	K11259306292	7.10	5.60
QCTC ER 25 8.0 X 6.30	K11259306303	8.00	6.30
QCTC ER 25 9.0 X 7.10	K11259306304	9.00	7.10
QCTC ER 25 10.0 X 8.0	K11259306283	10.00	8.00

As per (DIN) Standards

QCTC ER 25 3.5 X 2.7	K11259306276	3.50	2.70
QCTC ER 25 4.0 X 3.0	K11259306277	4.00	3.00
QCTC ER 25 4.5 X 3.4	K11259306278	4.50	3.40
QCTC ER 25 6.0 X 4.9	K11259306279	6.00	4.90
QCTC ER 25 7.0 X 5.5	K11259306280	7.00	5.50
QCTC ER 25 8.0 X 6.2	K11259306281	8.00	6.20
QCTC ER 25 9.0 X 7.0	K11259306282	9.00	7.00
QCTC ER 25 10.0 X 8.0	K11259306283	10.00	8.00

As per (JIS) Standards

QCTC ER 25 4.0 X 3.0	K11259306277	4.00	3.00
QCTC ER 25 4.0 X 3.20	K11259306306	4.00	3.20
QCTC ER 25 5.0 X 4.0	K11259306301	5.00	4.00
QCTC ER 25 5.50 X 4.50	K11259306307	5.50	4.50
QCTC ER 25 6.0 X 4.50	K11259306308	6.00	4.50
QCTC ER 25 6.10 X 5.0	K11259306309	6.10	5.00
QCTC ER 25 6.20 X 5.0	K11259306310	6.20	5.00
QCTC ER 25 7.0 X 5.5	K11259306280	7.00	5.50
QCTC ER 25 8.0 X 6.0	K11259306311	8.00	6.00
QCTC ER 25 8.0 X 6.2	K11259306281	8.00	6.20
QCTC ER 25 8.50 X 6.50	K11259306312	8.50	6.50
QCTC ER 25 9.0 X 7.0	K11259306282	9.00	7.00

Note: All Dimensions are in mm
For DIN Standard Numbers and more technical details please see page number 281 - 284

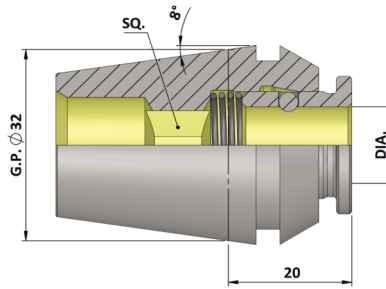

QCTC ER 32

As per (ISO) (529 -1975) Standards

Item Name	Item Code	Dia	Square
QCTC ER 32 3.15 X 2.50	K11259307297	3.15	2.50
QCTC ER 32 3.55 X 2.80	K11259307298	3.55	2.80
QCTC ER 32 4.0 X 3.15	K11259307300	4.00	3.15
QCTC ER 32 4.50 X 3.55	K11259307299	4.50	3.55
QCTC ER 32 5.0 X 4.0	K11259307301	5.00	4.00
QCTC ER 32 5.60 X 4.50	K11259307302	5.60	4.50
QCTC ER 32 6.3 X 5.0	K11259307291	6.30	5.00
QCTC ER 32 7.10 X 5.60	K11259307292	7.10	5.60
QCTC ER 32 8.0 X 6.30	K11259307303	8.00	6.30
QCTC ER 32 9.0 X 7.10	K11259307304	9.00	7.10
QCTC ER 32 10.0 X 8.0	K11259307283	10.00	8.00
QCTC ER 32 11.2 X 9.0	K11259307293	11.20	9.00
QCTC ER 32 12.5 X 10.0	K11259307294	12.50	10.00
QCTC ER 32 14.0 X 11.20	K11259307305	14.00	11.20

As per (DIN) Standards

QCTC ER 32 3.5 X 2.7	K11259307276	3.50	2.70
QCTC ER 32 4.0 X 3.0	K11259307277	4.00	3.00
QCTC ER 32 4.5 X 3.4	K11259307278	4.50	3.40
QCTC ER 32 6.0 X 4.9	K11259307279	6.00	4.90
QCTC ER 32 7.0 X 5.5	K11259307280	7.00	5.50
QCTC ER 32 8.0 X 6.2	K11259307281	8.00	6.20
QCTC ER 32 9.0 X 7.0	K11259307287	9.00	7.00
QCTC ER 32 10.0 X 8.0	K11259307283	10.00	8.00
QCTC ER 32 11.0 X 9.0	K11259307284	11.00	9.00
QCTC ER 32 12.0 X 9.0	K11259307285	12.00	9.00
QCTC ER 32 14.0 X 11.0	K11259307286	14.00	11.00

Note: All Dimensions are in mm
For DIN Standard Numbers and more technical details please see page number 281 - 284

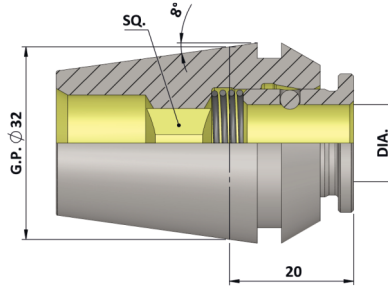

QCTC ER 32

As per (JIS) Standards

Item Name	Item Code	Dia	Square
QCTC ER 32 4.0 X 3.0	K11259307277	4.00	3.00
QCTC ER 32 4.0 X 3.20	K11259307306	4.00	3.20
QCTC ER 32 5.0 X 4.0	K11259307301	5.00	4.00
QCTC ER 32 5.50 X 4.50	K11259307307	5.50	4.50
QCTC ER 32 6.0 X 4.50	K11259307308	6.00	4.50
QCTC ER 32 6.10 X 5.0	K11259307309	6.10	5.00
QCTC ER 32 6.20 X 5.0	K11259307310	6.20	5.00
QCTC ER 32 7.0 X 5.5	K11259307280	7.00	5.50
QCTC ER 32 8.0 X 6.0	K11259307311	8.00	6.00
QCTC ER 32 8.0 X 6.2	K11259307281	8.00	6.20
QCTC ER 32 8.50 X 6.50	K11259307312	8.50	6.50
QCTC ER 32 9.0 X 7.0	K11259307287	9.00	7.00
QCTC ER 32 10.50 X 8.0	K11259307313	10.50	8.00
QCTC ER 32 11.0 X 9.0	K11259307284	11.00	9.00
QCTC ER 32 12.0 X 9.0	K11259307285	12.00	9.00
QCTC ER 32 12.5 X 10.0	K11259307294	12.50	10.00
QCTC ER 32 14.0 X 11.0	K11259307286	14.00	11.00

Note: All Dimensions are in mm
For DIN Standard Numbers and more technical details please see page number 281- 284

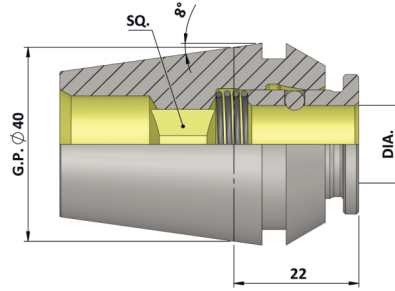

QCTC ER 40

As per (ISO) (529 -1975) Standards

Item Name	Item Code	Dia	Square
QCTC ER 40 3.15 X 2.50	K11259308297	3.15	2.50
QCTC ER 40 3.55 X 2.80	K11259308298	3.55	2.80
QCTC ER 40 4.0 X 3.15	K11259308300	4.00	3.15
QCTC ER 40 4.50 X 3.55	K11259308299	4.50	3.55
QCTC ER 40 5.0 X 4.0	K11259308301	5.00	4.00
QCTC ER 40 5.60 X 4.50	K11259308302	5.60	4.50
QCTC ER 40 6.3 X 5.0	K11259308291	6.30	5.00
QCTC ER 40 7.10 X 5.60	K11259308292	7.10	5.60
QCTC ER 40 8.0 X 6.30	K11259308303	8.00	6.30
QCTC ER 40 9.0 X 7.10	K11259308304	9.00	7.10
QCTC ER 40 10.0 X 8.0	K11259308283	10.00	8.00
QCTC ER 40 11.2 X 9.0	K11259308293	11.20	9.00
QCTC ER 40 12.5 X 10.0	K11259308294	12.50	10.00
QCTC ER 40 14.0 X 11.20	K11259308286	14.00	11.20
QCTC ER 40 16.0 X 12.5	K11259308295	16.00	12.50
QCTC ER 40 18.0 X 14.0	K11259308289	18.00	14.00

As per (DIN) Standards

QCTC ER 40 3.5 X 2.7	K11259308276	3.50	2.70
QCTC ER 40 4.0 X 3.0	K11259308277	4.00	3.00
QCTC ER 40 4.5 X 3.4	K11259308278	4.50	3.40
QCTC ER 40 6.0 X 4.9	K11259308279	6.00	4.90
QCTC ER 40 7.0 X 5.5	K11259308280	7.00	5.50
QCTC ER 40 8.0 X 6.2	K11259308281	8.00	6.20
QCTC ER 40 9.0 X 7.0	K11259308282	9.00	7.00
QCTC ER 40 10.0 X 8.0	K11259308283	10.00	8.00
QCTC ER 40 11.0 X 9.0	K11259308284	11.00	9.00
QCTC ER 40 12.0 X 9.0	K11259308285	12.00	9.00
QCTC ER 40 14.0 X 11.0	K11259240286	14.00	11.00
QCTC ER 40 16.0 X 12.0	K11259308288	16.00	12.00
QCTC ER 40 18.0 X 14.5	K11259308296	18.00	14.50

Note: All Dimensions are in mm
For DIN Standard Numbers and more technical details please see page number 281 - 284

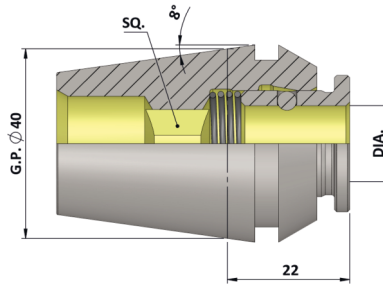

QCTC ER 40

As per (JIS) Standards

Item Name	Item Code	Dia	Square
QCTC ER 40 4.0 X 3.0	K11259308277	4.00	3.00
QCTC ER 40 4.0 X 3.20	K11259308306	4.00	3.20
QCTC ER 40 5.0 X 4.0	K11259308301	5.00	4.00
QCTC ER 40 5.50 X 4.50	K11259308307	5.50	4.50
QCTC ER 40 6.0 X 4.50	K11259308308	6.00	4.50
QCTC ER 40 6.10 X 5.0	K11259308309	6.10	5.00
QCTC ER 40 6.20 X 5.0	K11259308310	6.20	5.00
QCTC ER 40 7.0 X 5.5	K11259308280	7.00	5.50
QCTC ER 40 8.0 X 6.0	K11259308311	8.00	6.00
QCTC ER 40 8.0 X 6.2	K11259308281	8.00	6.20
QCTC ER 40 8.50 X 6.50	K11259308312	8.50	6.50
QCTC ER 40 9.0 X 7.0	K11259308282	9.00	7.00
QCTC ER 40 10.50 X 8.0	K11259308313	10.50	8.00
QCTC ER 40 11.0 X 9.0	K11259308284	11.00	9.00
QCTC ER 40 12.0 X 9.0	K11259308285	12.00	9.00
QCTC ER 40 12.5 X 10.0	K11259308294	12.50	10.00
QCTC ER 40 13.0 X 10.0	K11259308314	13.00	10.00
QCTC ER 40 14.0 X 11.0	K11259240286	14.00	11.00
QCTC ER 40 15.0 X 12.0	K11259308315	15.00	12.00
QCTC ER 40 16.0 X 12.0	K11259308288	16.00	12.00
QCTC ER 40 18.0 X 14.0	K11259308289	18.00	14.00

Note: All Dimensions are in mm
For DIN Standard Numbers and more technical details please see page number 281 - 284

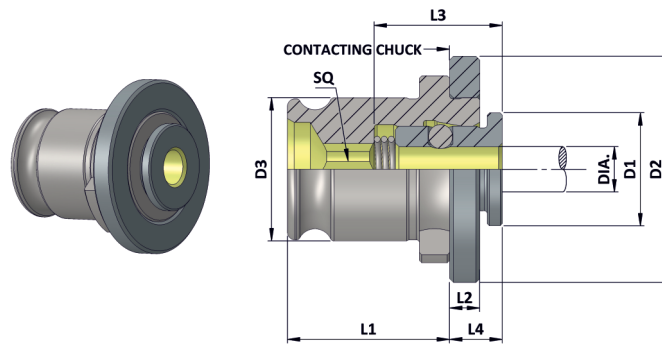

Technical Information

Item Name	Capacity	Shank Dia.	Suitable Chuck Size	D1	D2	D3	L1	L2	L3	L4
KWE 0	M1 - M10	2.5 - 8.0	0	13	22	13	19.5	4	15	7
KWE 1	M3 - M12	3.5 - 11.2	1	19	30	19	21.5	4	17	7
KWE 2	M8 - M20	6 - 18	2	30	48	31	35	5	30	11

Note: All Dimensions are in mm

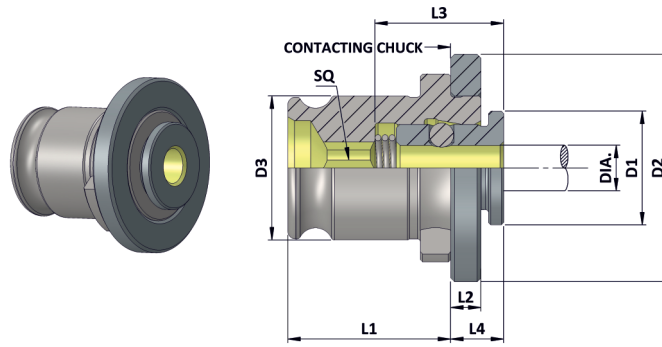

KWE0 Tap Adaptor

Item Name	Capacity	Shank Dia.	Suitable Chuck Size	D1	D2	D3	L1	L2	L3	L4
KWE 0	M1 - M10	2.5 - 8.0	0	13	22	13	19.5	4	15	7

As per (ISO) (529 -1975) Standards

Item Name	Item Code	Dia	Square
KWE0 DIA 3.15 SQ 2.50	K11128118193	3.15	2.50
KWE0 DIA 3.55 SQ 2.80	K11128119193	3.55	2.80
KWE0 DIA 4.00 SQ 3.15	K11128120193	4.00	3.15
KWE0 DIA 4.50 SQ 3.55	K11128121193	4.50	3.55
KWE0 DIA 5.00 SQ 4.00	K11128122193	5.00	4.00
KWE0 DIA 5.60 SQ 4.50	K11128123193	5.60	4.50
KWE0 DIA 6.30 SQ 5.00	K11128124193	6.30	5.00
KWE0 DIA 7.10 SQ 5.60	K11128125193	7.10	5.60
KWE0 DIA 8.00 SQ 6.30	K11128126193	8.00	6.30

As per (DIN) Standards

KWE0 DIA 2.50 SQ 2.10	K11128141193	2.50	2.10
KWE0 DIA 2.80 SQ 2.10	K11128142193	2.80	2.10
KWE0 DIA 3.50 SQ 2.70	K11128143193	3.50	2.70
KWE0 DIA 4.00 SQ 3.00	K11128144193	4.00	3.00
KWE0 DIA 4.50 SQ 3.40	K11128145193	4.50	3.40
KWE0 DIA 6.00 SQ 4.90	K11128146193	6.00	4.90
KWE0 DIA 7.00 SQ 5.50	K11128147193	7.00	5.50
KWE0 DIA 8.00 SQ 6.20	K11128148193	8.00	6.20

Note: All Dimensions are in mm
For DIN Standard Numbers and more technical details please see page number 281 - 284

Continued...



As per (JIS) Standards

Item Name	Item Code	Dia	Square
KWEO DIA 3.00 SQ 2.50	K11128162193	3.00	2.50
KWEO DIA 4.00 SQ 3.00	K11128144193	4.00	3.00
KWEO DIA 4.00 SQ 3.20	K11128163193	4.00	3.20
KWEO DIA 5.00 SQ 4.00	K11128122193	5.00	4.00
KWEO DIA 5.50 SQ 4.50	K11128164193	5.50	4.50
KWEO DIA 6.00 SQ 4.50	K11128165193	6.00	4.50
KWEO DIA 6.10 SQ 5.00	K11128166193	6.10	5.00
KWEO DIA 6.20 SQ 5.00	K11128167193	6.20	5.00
KWEO DIA 7.00 SQ 5.50	K11128147193	7.00	5.50
KWEO DIA 8.00 SQ 6.00	K11128168193	8.00	6.00
KWEO DIA 8.00 SQ 6.20	K11128148193	8.00	6.20

As per (ANSI) (US) Standards

KWEO DIA 0.141" SQ 0.110"	K11128191193	0.141"	0.110"
KWEO DIA 0.168" SQ 0.131"	K11128192193	0.168"	0.131"
KWEO DIA 0.194" SQ 0.152"	K11128198193	0.194"	0.152"
KWEO DIA 0.220" SQ 0.165"	K11128199193	0.220"	0.165"
KWEO DIA 0.255" SQ 0.191"	K11128200193	0.255"	0.191"

Note: All Dimensions are in mm
For DIN Standard Numbers and more technical details please see page number 281 - 284

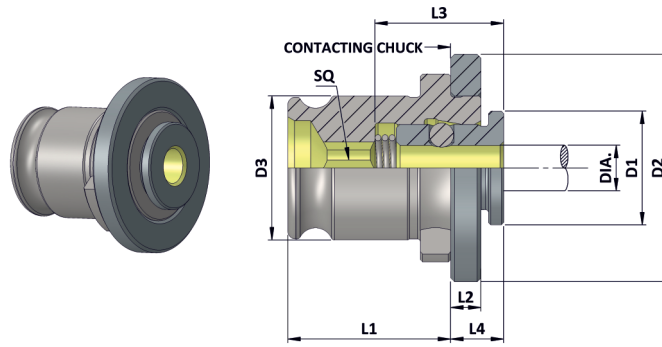

KWE1 Tap Adaptor

Item Name	Capacity	Shank Dia.	Suitable Chuck Size	D1	D2	D3	L1	L2	L3	L4
KWE 1	M3 - M12	3.5 - 11.2	1	19	30	19	21.5	4	17	7

As per (ISO) (529 -1975) Standards

Item Name	Item Code	Dia	Square
KWE1 DIA 3.15 SQ 2.50	K11129118193	3.15	2.50
KWE1 DIA 3.55 SQ 2.80	K11129119193	3.55	2.80
KWE1 DIA 4.00 SQ 3.15	K11129120193	4.00	3.15
KWE1 DIA 4.50 SQ 3.55	K11129121193	4.50	3.55
KWE1 DIA 5.00 SQ 4.00	K11129122193	5.00	4.00
KWE1 DIA 5.60 SQ 4.50	K11129123193	5.60	4.50
KWE1 DIA 6.30 SQ 5.00	K11129124193	6.30	5.00
KWE1 DIA 7.10 SQ 5.60	K11129125193	7.10	5.60
KWE1 DIA 8.00 SQ 6.30	K11129126193	8.00	6.30
KWE1 DIA 9.00 SQ 7.10	K11129127193	9.00	7.10
KWE1 DIA 10.00 SQ 8.00	K11129128193	10.00	8.00
KWE1 DIA 11.20 SQ 9.00	K11129129193	11.20	9.00

As per (DIN) Standards

KWE1 DIA 2.50 SQ 2.10	K11129141193	2.50	2.10
KWE1 DIA 2.80 SQ 2.10	K11129142193	2.80	2.10
KWE1 DIA 3.50 SQ 2.70	K11129143193	3.50	2.70
KWE1 DIA 4.00 SQ 3.00	K11129144193	4.00	3.00
KWE1 DIA 4.50 SQ 3.40	K11129145193	4.50	3.40
KWE1 DIA 6.00 SQ 4.90	K11129146193	6.00	4.90
KWE1 DIA 7.00 SQ 5.50	K11129147193	7.00	5.50
KWE1 DIA 8.00 SQ 6.20	K11129148193	8.00	6.20
KWE1 DIA 9.00 SQ 7.00	K11129149193	9.00	7.00
KWE1 DIA 10.00 SQ 8.00	K11129128193	10.00	8.00
KWE1 DIA 11.00 SQ 9.00	K11129150193	11.00	9.00

Note: All Dimensions are in mm
For DIN Standard Numbers and more technical details please see page number 281 - 284

Continued...



As per (JIS) Standards

Item Name	Item Code	Dia	Square
KWE1 DIA 3.00 SQ 2.50	K11129162193	3.00	2.50
KWE1 DIA 4.00 SQ 3.00	K11129144193	4.00	3.00
KWE1 DIA 4.00 SQ 3.20	K11129163193	4.00	3.20
KWE1 DIA 5.00 SQ 4.00	K11129122193	5.00	4.00
KWE1 DIA 5.50 SQ 4.50	K11129164193	5.50	4.50
KWE1 DIA 6.00 SQ 4.50	K11129165193	6.00	4.50
KWE1 DIA 6.10 SQ 5.00	K11129166193	6.10	5.00
KWE1 DIA 6.20 SQ 5.00	K11129167193	6.20	5.00
KWE1 DIA 7.00 SQ 5.50	K11129147193	7.00	5.50
KWE1 DIA 8.00 SQ 6.00	K11129168193	8.00	6.00
KWE1 DIA 8.00 SQ 6.20	K11129148193	8.00	6.20
KWE1 DIA 8.50 SQ 6.50	K11129170193	8.50	6.50
KWE1 DIA 9.00 SQ 7.00	K11129149193	9.00	7.00
KWE1 DIA 9.50 SQ 7.00	K11129171193	9.50	7.00
KWE1 DIA 10.50 SQ 8.00	K11129172193	10.50	8.00
KWE1 DIA 11.00 SQ 9.00	K11129150193	11.00	9.00

As per (ANSI) (US) Standards

KWE1 DIA 0.141" SQ 0.110"	K11129191193	0.141"	0.110"
KWE1 DIA 0.141" SQ 0.110" TC	K11129191249	0.141"	0.110"
KWE1 DIA 0.168" SQ 0.131"	K11129192193	0.168"	0.131"
KWE1 DIA 0.168" SQ 0.131" TC	K11129192249	0.168"	0.131"
KWE1 DIA 0.194" SQ 0.152"	K11129198193	0.194"	0.152"
KWE1 DIA 0.194" SQ 0.152" NO-10 TC	K11236198193	0.194"	0.152"
KWE1 DIA 0.220" SQ 0.165"	K11129199193	0.220"	0.165"
KWE1 DIA 0.220" SQ 0.165" TC	K11129199249	0.220"	0.165"
KWE1 DIA 0.255" SQ 0.191"	K11129200193	0.255"	0.191"
KWE1 DIA 0.255" SQ 0.191" 1/4" TC	K11236200193	0.255"	0.191"
KWE1 DIA 0.313" SQ 0.234"	K11129201193	0.313"	0.234"
KWE1 DIA 0.318" SQ 0.238" 5/16" TC	K11236202193	0.318"	0.238"
KWE1 DIA 0.318" SQ 0.238"	K11129202193	0.318"	0.238"
KWE1 DIA 0.323" SQ 0.242"	K11129193193	0.323"	0.242"
KWE1 DIA 0.323" SQ 0.242" TC	K11129193249	0.323"	0.242"
KWE1 DIA 0.367" SQ 0.275"	K11129194193	0.367"	0.275"
KWE1 DIA 0.367" SQ 0.275" TC	K11129194249	0.367"	0.275"
KWE1 DIA 0.381" SQ 0.286"	K11129195193	0.381"	0.286"
KWE1 DIA 0.381" SQ 0.286" 3/8" TC	K11236195193	0.381"	0.286"
KWE1 DIA 0.429" SQ 0.322"	K11129196193	0.429"	0.322"
KWE1 DIA 0.429" SQ 0.322" TC	K11129196249	0.429"	0.322"
KWE1 DIA 0.437" SQ 0.328"	K11129197193	0.437"	0.328"
KWE1 DIA 0.437" SQ 0.328" TC	K11129197249	0.437"	0.328"

Note: All Dimensions are in mm
For DIN Standard Numbers and more technical details please see page number 281 - 284

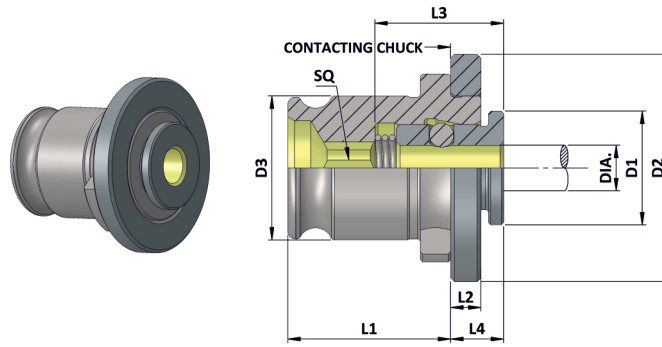

Technical Information

Item Name	Capacity	Shank Dia.	Suitable Chuck Size	D1	D2	D3	L1	L2	L3	L4
KWE 2	M8 - M20	6 - 18	2	30	48	31	35	5	30	11

As per (ISO) (529 -1975) Standards

Item Name	Item Code	Dia	Square
KWE2 DIA 6.30 SQ 5.00	K11130124193	6.30	5.00
KWE2 DIA 7.10 SQ 5.60	K11130125193	7.10	5.60
KWE2 DIA 8.00 SQ 6.30	K11130126193	8.00	6.30
KWE2 DIA 9.00 SQ 7.10	K11130127193	9.00	7.10
KWE2 DIA 10.00 SQ 8.00	K11130128193	10.00	8.00
KWE2 DIA 11.20 SQ 9.00	K11130129193	11.20	9.00
KWE2 DIA 12.50 SQ 10.00	K11130130193	12.50	10.00
KWE2 DIA 14.00 SQ 11.20	K11130131193	14.00	11.20
KWE2 DIA 16.00 SQ 12.50	K11130132193	16.00	12.50
KWE2 DIA 18.00 SQ 14.00	K11130133193	18.00	14.00

As per (DIN) Standards

KWE2 DIA 6.00 SQ 4.90	K11130146193	6.00	4.90
KWE2 DIA 7.00 SQ 5.50	K11130147193	7.00	5.50
KWE2 DIA 8.00 SQ 6.20	K11130148193	8.00	6.20
KWE2 DIA 9.00 SQ 7.00	K11130149193	9.00	7.00
KWE2 DIA 10.00 SQ 8.00	K11130128193	10.00	8.00
KWE2 DIA 11.00 SQ 9.00	K11130150193	11.00	9.00
KWE2 DIA 12.00 SQ 9.00	K11130151193	12.00	9.00
KWE2 DIA 14.00 SQ 11.00	K11130152193	14.00	11.00
KWE2 DIA 16.00 SQ 12.00	K11130153193	16.00	12.00
KWE2 DIA 18.00 SQ 14.50	K11130154193	18.00	14.50

Note: All Dimensions are in mm
For DIN Standard Numbers and more technical details please see page number 281 - 284



As per (JIS) Standards

Item Name	Item Code	Dia	Square
KWE2 DIA 6.00 SQ 4.50	K11130165193	6.00	4.50
KWE2 DIA 6.10 SQ 5.00	K11130166193	6.10	5.00
KWE2 DIA 6.20 SQ 5.00	K11130167193	6.20	5.00
KWE2 DIA 7.00 SQ 5.50	K11130147193	7.00	5.50
KWE2 DIA 8.00 SQ 6.00	K11130168193	8.00	6.00
KWE2 DIA 8.00 SQ 6.20	K11130148193	8.00	6.20
KWE2 DIA 8.50 SQ 6.50	K11130170193	8.50	6.50
KWE2 DIA 9.00 SQ 7.00	K11130149193	9.00	7.00
KWE2 DIA 9.50 SQ 7.00	K11130171193	9.50	7.00
KWE2 DIA 10.50 SQ 8.00	K11130172193	10.50	8.00
KWE2 DIA 11.00 SQ 9.00	K11130150193	11.00	9.00
KWE2 DIA 12.00 SQ 9.00	K11130151193	12.00	9.00
KWE2 DIA 12.50 SQ 10.00	K11130130193	12.50	10.00
KWE2 DIA 13.00 SQ 10.00	K11130173193	13.00	10.00
KWE2 DIA 14.00 SQ 11.00	K11130152193	14.00	11.00
KWE2 DIA 15.00 SQ 12.00	K11130174193	15.00	12.00
KWE2 DIA 16.00 SQ 12.00	K11130153193	16.00	12.00
KWE2 DIA 17.00 SQ 13.00	K11130175193	17.00	13.00
KWE2 DIA 18.00 SQ 14.00	K11130133193	18.00	14.00

Note: All Dimensions are in mm
For DIN Standard Numbers and more technical details please see page number 281 - 284



As per (ANSI) (US) Standards

Item Name	Item Code	Dia	Square
KWE2 DIA 0.141" SQ 0.110"	K11130191193	0.141"	0.110"
KWE2 DIA 0.168" SQ 0.131"	K11130192193	0.168"	0.131"
KWE2 DIA 0.194" SQ 0.152"	K11130198193	0.194"	0.152"
KWE2 DIA 0.220" SQ 0.165"	K11130199193	0.220"	0.165"
KWE2 DIA 0.255" SQ 0.191"	K11130200193	0.255"	0.191"
KWE2 DIA 0.313" SQ 0.234"	K11130201193	0.313"	0.234"
KWE2 DIA 0.318" SQ 0.238"	K11130202193	0.318"	0.238"
KWE2 DIA 0.318" SQ 0.238" 5/16" TC	K11234202193	0.318"	0.238"
KWE2 DIA 0.323" SQ 0.242"	K11130193193	0.323"	0.242"
KWE2 DIA 0.323" SQ 0.242" 7/16" TC	K11234193193	0.323"	0.242"
KWE2 DIA 0.367" SQ 0.275"	K11130194193	0.367"	0.275"
KWE2 DIA 0.367" SQ 0.275" 1/2" TC	K11234194193	0.367"	0.275"
KWE2 DIA 0.381" SQ 0.286"	K11130195193	0.381"	0.286"
KWE2 DIA 0.381" SQ 0.286" 3/8" TC	K11234195234	0.381"	0.286"
KWE2 DIA 0.429" SQ 0.322"	K11130196193	0.429"	0.322"
KWE2 DIA 0.429" SQ 0.322" TC	K11130196249	0.429"	0.322"
KWE2 DIA 0.437" SQ 0.328"	K11130197193	0.437"	0.328"
KWE2 DIA 0.480" SQ 0.360"	K11130203193	0.480"	0.360"
KWE2 DIA 0.480" SQ 0.360" 5/8" TC	K11234203193	0.480"	0.360"
KWE2 DIA 0.542" SQ 0.406"	K11130204193	0.542"	0.406"
KWE2 DIA 0.542" SQ 0.406" TC	K11130204249	0.542"	0.406"
KWE2 DIA 0.562" SQ 0.421"	K11130205193	0.562"	0.421"
KWE2 DIA 0.562" SQ 0.421" TC	K11130205249	0.562"	0.421"
KWE2 DIA 0.590" SQ 0.442"	K11130206193	0.590"	0.442"
KWE2 DIA 0.590" SQ 0.442" 3/4" TC	K11234206235	0.590"	0.442"
KWE2 DIA 0.652" SQ 0.489"	K11130207193	0.652"	0.489"
KWE2 DIA 0.652" SQ 0.489" TC	K11130207249	0.652"	0.489"
KWE2 DIA 0.687" SQ 0.515"	K11130208193	0.687"	0.515"
KWE2 DIA 0.687" SQ 0.515" 1/2" P TC	K11234208173	0.687"	0.515"
KWE2 DIA 0.697" SQ 0.523"	K11130209193	0.697"	0.523"
KWE2 DIA 0.697" SQ 0.523" TC	K11130209249	0.697"	0.523"
KWE2 DIA 0.700" SQ 0.531"	K11130210193	0.700"	0.531"
KWE2 DIA 0.700" SQ 0.531" TC	K11130210249	0.700"	0.531"

Note: All Dimensions are in mm
For DIN Standard Numbers and more technical details please see page number 281 - 284

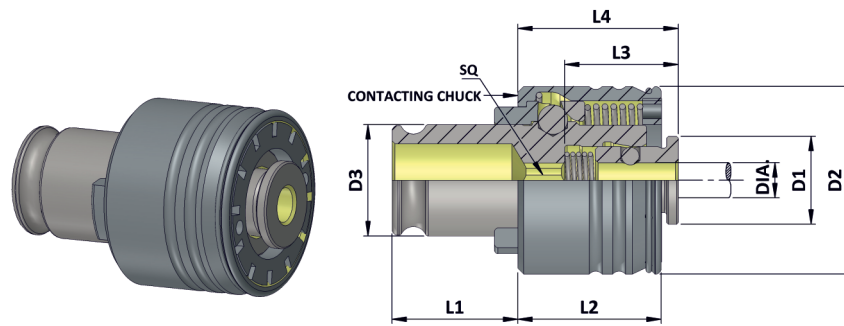

Technical Information

Item Name	Capacity	Shank Dia.	Suitable Chuck Size	D1	D2	D3	L1	L2	L3	L4
KWES 0 B	M1 - M10	2.5 - 8.0	0	13	23	13	19.5	20	15	21
KWES 1 B	M3 - M12	3.5 - 11.2	1	19	32	19	21.5	25	17	25
KWES 2 B	M8 - M20	6 - 18	2	30	50	31	35	31	30	34
KWES 3 B	M14 - M33	11 - 28	3	48	72	48	55.5	41	44	45
KWES 4 B	M22 - M48	18 - 36	4	60	95	60	63	61	71	68

Application :

- Quick Change Tap Adaptor KWES../B are used along with KTA Quick Change Tapping Chuc on CNC Lathe, CNC Milling & Manual Lathe & Drilling Machines.

Features :

- Taps can be changed quickly without additional tooling Support.
Different Adaptor is required for each tap, depends on Tap shank dia & square size.
- Safety cluth protects tap breakages. Blind holes tapping becomes easy.

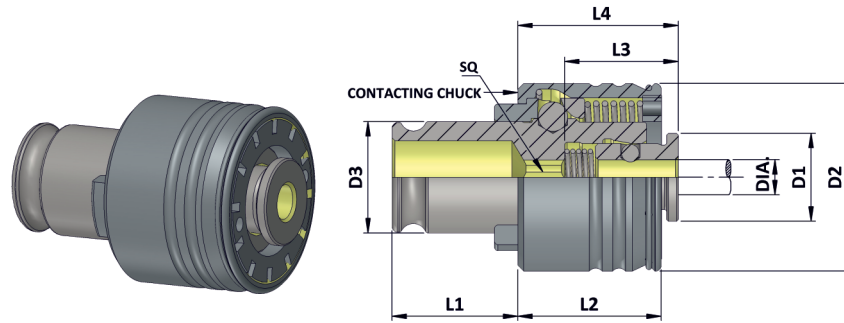

KWES0B Tap Adaptor

Item Name	Capacity	Shank Dia.	Suitable Chuck Size	D1	D2	D3	L1	L2	L3	L4
KWES 0 B	M1 - M10	2.5 - 8.0	0	13	23	13	19.5	20	15	21

As per (ISO) (529 -1975) Standards

Item Name	Item Code	Dia	Square
KWES0B DIA 3.15 SQ 2.50 M3	K11132118104	3.15	2.50
KWES0B DIA 3.15 SQ 2.50 M4	K11132118105	3.15	2.50
KWES0B DIA 3.55 SQ 2.80 M3.5	K11132119106	3.55	2.80
KWES0B DIA 3.55 SQ 2.80 M4.5	K11132119107	3.55	2.80
KWES0B DIA 4.00 SQ 3.15 M4	K11132120105	4.00	3.15
KWES0B DIA 4.00 SQ 3.15 M5	K11132120108	4.00	3.15
KWES0B DIA 4.50 SQ 3.55 M6	K11132121109	4.50	3.55
KWES0B DIA 5.00 SQ 4.00 M5	K11132122108	5.00	4.00
KWES0B DIA 5.60 SQ 4.50 M7	K11132123110	5.60	4.50
KWES0B DIA 6.30 SQ 5.00 M6	K11132124109	6.30	5.00
KWES0B DIA 6.30 SQ 5.00 M8	K11132124111	6.30	5.00
KWES0B DIA 7.10 SQ 5.60 M10	K11132125112	7.10	5.60
KWES0B DIA 8.00 SQ 6.30 M8	K11132126111	8.00	6.30
KWES0B DIA 8.00 SQ 6.30 M10	K11132126112	8.00	6.30
KWES0B DIA 3.15 SQ 2.50 NO. 04UNC	K11132118188	3.15	2.50
KWES0B DIA 3.15 SQ 2.50 NO. 05UNC	K11132118189	3.15	2.50
KWES0B DIA 3.15 SQ 2.50 NO. 08UNC	K11132118156	3.15	2.50
KWES0B DIA 3.55 SQ 2.80 3/16" UNC	K11132119196	3.55	2.80
KWES0B DIA 3.55 SQ 2.80 NO. 06UNC	K11132119155	3.55	2.80
KWES0B DIA 3.55 SQ 2.80 NO. 10UNC	K11132119157	3.55	2.80
KWES0B DIA 4.00 SQ 3.15 7/32" UNC	K11132120197	4.00	3.15
KWES0B DIA 4.00 SQ 3.15 NO. 12UNC	K11132120158	4.00	3.15
KWES0B DIA 4.50 SQ 3.55 1/4" UNC	K11132121159	4.50	3.55
KWES0B DIA 4.50 SQ 3.55 NO. 08UNC	K11132121156	4.50	3.55
KWES0B DIA 5.00 SQ 4.00 3/16" UNC	K11132122196	5.00	4.00
KWES0B DIA 5.00 SQ 4.00 NO. 10UNC	K11132122157	5.00	4.00
KWES0B DIA 5.60 SQ 4.50 7/32" UNC	K11132123197	5.60	4.50
KWES0B DIA 5.60 SQ 4.50 NO. 12UNC	K11132123158	5.60	4.50
KWES0B DIA 6.30 SQ 5.00 1/4" UNC	K11132124159	6.30	5.00
KWES0B DIA 6.30 SQ 5.00 5/16" UNC	K11132124161	6.30	5.00
KWES0B DIA 7.10 SQ 5.60 3/8" UNC	K11132125164	7.10	5.60
KWES0B DIA 8.00 SQ 6.30 5/16" UNC	K11132126161	8.00	6.30

Note: All Dimensions are in mm
For DIN Standard Numbers and more technical details please see page number 281 - 284

Continued...



As per (DIN) Standards

Item Name	Item Code	Dia	Square
WESOB DIA 2.50 SQ 2.10 M1	K11132141135	2.50	2.10
KWESOB DIA 2.50 SQ 2.10 M1.8	K11132141136	2.50	2.10
KWESOB DIA 2.80 SQ 2.10 M2	K11132142194	2.80	2.10
KWESOB DIA 2.80 SQ 2.10 M2.5	K11132142103	2.80	2.10
KWESOB DIA 2.80 SQ 2.10 M3	K11132142104	2.80	2.10
KWESOB DIA 2.80 SQ 2.10 M4	K11132142105	2.80	2.10
KWESOB DIA 2.80 SQ 2.24 M2.2	K11132223102	2.80	2.24
KWESOB DIA 2.80 SQ 2.24 M2.5	K11132223103	2.80	2.24
KWESOB DIA 3.50 SQ 2.70 M3	K11132143104	3.50	2.70
KWESOB DIA 3.50 SQ 2.70 M5	K11132143108	3.50	2.70
KWESOB DIA 4.00 SQ 3.00 M3.5	K11132144106	4.00	3.00
KWESOB DIA 4.00 SQ 3.00 M4	K11132144105	4.00	3.00
KWESOB DIA 4.50 SQ 3.40 M4	K11132145105	4.50	3.40
KWESOB DIA 4.50 SQ 3.40 M6	K11132145109	4.50	3.40
KWESOB DIA 6.00 SQ 4.90 M5	K11132146108	6.00	4.90
KWESOB DIA 6.00 SQ 4.90 M6	K11132146109	6.00	4.90
KWESOB DIA 6.00 SQ 4.90 M8	K11132146111	6.00	4.90
KWESOB DIA 7.00 SQ 5.50 M9	K11132147142	7.00	5.50
KWESOB DIA 7.00 SQ 5.50 M10	K11132147112	7.00	5.50
KWESOB DIA 8.00 SQ 6.20 M8	K11132148111	8.00	6.20
KWESOB DIA 2.50 SQ 2.10 NO.01 UNC	K11132141201	2.50	2.10
KWESOB DIA 2.80 SQ 2.10 3/32" UNC	K11132142202	2.80	2.10
KWESOB DIA 2.80 SQ 2.10 5/32" UNC	K11132142203	2.80	2.10
KWESOB DIA 3.50 SQ 2.70 1/8" UNC	K11132143207	3.50	2.70
KWESOB DIA 4.00 SQ 3.00 7/32" UNC	K11132144197	4.00	3.00
KWESOB DIA 4.50 SQ 3.40 1/4" UNC	K11132145159	4.50	3.40
KWESOB DIA 4.50 SQ 3.40 5/32" UNC	K11132145203	4.50	3.40
KWESOB DIA 7.00 SQ 5.50 1/4" UNC	K11132147159	7.00	5.50
KWESOB DIA 7.00 SQ 5.50 1/8" G(BSP)	K11132147207	7.00	5.50
KWESOB DIA 7.00 SQ 5.50 3/8" G(BSP)	K11132147206	7.00	5.50
KWESOB DIA 8.00 SQ 6.20 5/16" UNC	K11132148161	8.00	6.20

Note: All Dimensions are in mm
For DIN Standard Numbers and more technical details please see page number 281 - 284



As per (JIS) Standards

Item Name	Item Code	Dia	Square
KWESOB DIA 4.00 SQ 3.00 M3	K11132144104	4.00	3.00
KWESOB DIA 4.00 SQ 3.00 M3.5	K11132144106	4.00	3.00
KWESOB DIA 4.00 SQ 3.20 M3	K11132163104	4.00	3.20
KWESOB DIA 5.00 SQ 4.00 M4	K11132122105	5.00	4.00
KWESOB DIA 5.00 SQ 4.00 M4.5	K11132122107	5.00	4.00
KWESOB DIA 5.50 SQ 4.50 M4.5	K11132164107	5.50	4.50
KWESOB DIA 5.50 SQ 4.50 M5	K11132164108	5.50	4.50
KWESOB DIA 5.50 SQ 4.50 M5.5	K11132164141	5.50	4.50
KWESOB DIA 6.00 SQ 4.50 M6	K11132165109	6.00	4.50
KWESOB DIA 6.20 SQ 5.00 M7	K11132167110	6.20	5.00
KWESOB DIA 6.20 SQ 5.00 M8	K11132167111	6.20	5.00
KWESOB DIA 7.00 SQ 5.50 M9	K11132147142	7.00	5.50
KWESOB DIA 7.00 SQ 5.50 M10	K11132147112	7.00	5.50
KWESOB DIA 8.00 SQ 6.00 M11	K11132168143	8.00	6.00

As per (ANSI) (US) Standards

KWESOB DIA 0.141" SQ 0.110" NO. 06"UNC	K11132191155	0.141"	0.110"
KWESOB DIA 0.168" SQ 0.131" NO. 08" UNC	K11132192190	0.168"	0.131"
KWESOB DIA 0.194" SQ 0.152" NO. 10 UNC	K11132198157	0.194"	0.152"
KWESOB DIA 0.220" SQ 0.165" NO. 12 UNC	K11132199158	0.220"	0.165"
KWESOB DIA 0.255" SQ 0.191" 1/4" UNC	K11132200159	0.255"	0.191"

Note: All Dimensions are in mm
For DIN Standard Numbers and more technical details please see page number 281 - 284

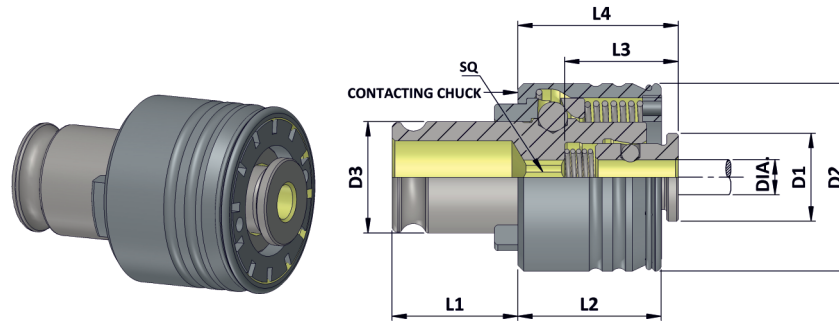

KWES1B Tap Adaptor

Item Name	Capacity	Shank Dia.	Suitable Chuck Size	D1	D2	D3	L1	L2	L3	L4
KWES 1 B	M3 - M12	3.5 - 11.2	1	19	32	19	21.5	25	17	25

As per (ISO) (529 -1975) Standards

Item Name	Item Code	Dia	Square
KWES1B DIA 3.15 SQ 2.50 M3	K11133118104	3.15	2.50
KWES1B DIA 3.15 SQ 2.50 M4	K11133118105	3.15	2.50
KWES1B DIA 3.55 SQ 2.80 M3	K11133119104	3.55	2.80
KWES1B DIA 3.55 SQ 2.80 M3.5	K11133119106	3.55	2.80
KWES1B DIA 3.55 SQ 2.80 M4.5	K11133119107	3.55	2.80
KWES1B DIA 4.00 SQ 3.15 M4	K11133120105	4.00	3.15
KWES1B DIA 4.00 SQ 3.15 M5	K11133120108	4.00	3.15
KWES1B DIA 4.50 SQ 3.55 M6	K11133121109	4.50	3.55
KWES1B DIA 5.00 SQ 4.00 M5	K11133122108	5.00	4.00
KWES1B DIA 5.60 SQ 4.50 M6	K11133123109	5.60	4.50
KWES1B DIA 5.60 SQ 4.50 M7	K11133123110	5.60	4.50
KWES1B DIA 6.30 SQ 5.00 M6	K11133124109	6.30	5.00
KWES1B DIA 6.30 SQ 5.00 M8	K11133124111	6.30	5.00
KWES1B DIA 7.10 SQ 5.60 M8	K11133125111	7.10	5.60
KWES1B DIA 7.10 SQ 5.60 M10	K11133125112	7.10	5.60
KWES1B DIA 8.00 SQ 6.30 M8	K11133126111	8.00	6.30
KWES1B DIA 8.00 SQ 6.30 M10	K11133126112	8.00	6.30
KWES1B DIA 9.00 SQ 7.10 M12	K11133127113	9.00	7.10
KWES1B DIA 10.00 SQ 8.00 M10	K11133128112	10.00	8.00
KWES1B DIA 11.20 SQ 9.00 M14	K11133129114	11.20	9.00
KWES1B DIA 3.15 SQ 2.50 NO. 04UNC	K11133118188	3.15	2.50
KWES1B DIA 3.15 SQ 2.50 NO. 05UNC	K11133118189	3.15	2.50
KWES1B DIA 3.15 SQ 2.50 NO. 08UNC	K11133118156	3.15	2.50
KWES1B DIA 3.55 SQ 2.80 NO. 06UNC	K11133119155	3.55	2.80
KWES1B DIA 3.55 SQ 2.80 NO. 10UNC	K11133119157	3.55	2.80
KWES1B DIA 3.55 SQ 2.80 3/16" UNC	K11133119196	3.55	2.80
KWES1B DIA 4.00 SQ 3.15 NO. 12UNC	K11133120158	4.00	3.15
KWES1B DIA 4.00 SQ 3.15 7/32" UNC	K11133120197	4.00	3.15
KWES1B DIA 4.50 SQ 3.55 NO. 08UNC	K11133121156	4.50	3.55
KWES1B DIA 4.50 SQ 3.55 1/4" UNC	K11133121159	4.50	3.55

Note: All Dimensions are in mm
For DIN Standard Numbers and more technical details please see page number 281 - 284



As per (ISO) (529 -1975) Standards

Item Name	Item Code	Dia	Square
KWES1B DIA 5.00 SQ 4.00 NO. 10UNC	K11133122157	5.00	4.00
KWES1B DIA 5.00 SQ 4.00 3/16" UNC	K11133122196	5.00	4.00
KWES1B DIA 5.60 SQ 4.50 NO. 12UNC	K11133123158	5.60	4.50
KWES1B DIA 5.60 SQ 4.50 7/32" UNC	K11133123197	5.60	4.50
KWES1B DIA 6.30 SQ 5.00 1/4" UNC	K11133124159	6.30	5.00
KWES1B DIA 6.30 SQ 5.00 5/16" UNC	K11133124161	6.30	5.00
KWES1B DIA 7.10 SQ 5.60 3/8" UNC	K11133125164	7.10	5.60
KWES1B DIA 8.00 SQ 6.30 5/16" UNC	K11133126161	8.00	6.30
KWES1B DIA 8.00 SQ 6.30 7/16" UNC	K11133126162	8.00	6.30
KWES1B DIA 9.00 SQ 7.10 1/2" UNC	K11133127163	9.00	7.10
KWES1B DIA 10.00 SQ 8.00 1/4" G(BSP)	K11133128205	10.00	8.00
KWES1B DIA 10.00 SQ 8.00 1/8 " (BSPT)	K11133128242	10.00	8.00
KWES1B DIA 10.00 SQ 8.00 3/8" UNC	K11133128164	10.00	8.00
KWES1B DIA 11.20 SQ 9.00 1/4" G(BSP)	K11133129205	11.20	9.00
KWES1B DIA 11.20 SQ 9.00 9/16" UNC	K11133129166	11.20	9.00

As per (DIN) Standards

KWES1B DIA 2.50 SQ 2.10 M1.6	K11133141239	2.50	2.10
KWES1B DIA 2.50 SQ 2.10 M1.8	K11133141136	2.50	2.10
KWES1B DIA 2.50 SQ 2.10 M2	K11133141194	2.50	2.10
KWES1B DIA 2.50 SQ 2.10 M2.5	K11133141103	2.50	2.10
KWES1B DIA 2.80 SQ 2.10 M2	K11133142194	2.80	2.10
KWES1B DIA 2.80 SQ 2.10 M2.5	K11133142103	2.80	2.10
KWES1B DIA 2.80 SQ 2.10 M3	K11133142104	2.80	2.10
KWES1B DIA 3.50 SQ 2.70 M3	K11133143104	3.50	2.70
KWES1B DIA 3.50 SQ 2.70 M4	K11133143105	3.50	2.70
KWES1B DIA 3.50 SQ 2.70 M5	K11133143108	3.50	2.70
KWES1B DIA 4.00 SQ 3.00 M3.5	K11133144106	4.00	3.00
KWES1B DIA 4.00 SQ 3.00 M4	K11133144105	4.00	3.00
KWES1B DIA 4.50 SQ 3.40 M4	K11133145105	4.50	3.40
KWES1B DIA 4.50 SQ 3.40 M6	K11133145109	4.50	3.40
KWES1B DIA 5.50 SQ 4.30 M7	K11133271110	5.50	4.30
KWES1B DIA 6.00 SQ 4.90 M5	K11133146108	6.00	4.90
KWES1B DIA 6.00 SQ 4.90 M6	K11133146109	6.00	4.90
KWES1B DIA 6.00 SQ 4.90 M8	K11133146111	6.00	4.90
KWES1B DIA 7.00 SQ 5.50 M7	K11133147110	7.00	5.50
KWES1B DIA 7.00 SQ 5.50 M9	K11133147142	7.00	5.50
KWES1B DIA 7.00 SQ 5.50 M10	K11133147112	7.00	5.50
KWES1B DIA 8.00 SQ 6.20 M8	K11133148111	8.00	6.20
KWES1B DIA 8.00 SQ 6.20 M10	K11133148112	8.00	6.20
KWES1B DIA 9.00 SQ 7.00 M12	K11133149113	9.00	7.00
KWES1B DIA 10.00 SQ 8.00 M10	K11133128112	10.00	8.00
KWES1B DIA 11.00 SQ 9.00 M14	K11133150114	11.00	9.00

Note: All Dimensions are in mm
For DIN Standard Numbers and more technical details please see page number 281 - 284

Continued...



As per (DIN) Standards

Item Name	Item Code	Dia	Square
KWES1B DIA 2.50 SQ 2.10 1/16" UNC	K11133141201	2.50	2.10
KWES1B DIA 2.80 SQ 2.10 3/32" UNC	K11133142202	2.80	2.10
KWES1B DIA 2.80 SQ 2.10 5/32" UNC	K11133142203	2.80	2.10
KWES1B DIA 3.50 SQ 2.70 1/8" UNC	K11133143207	3.50	2.70
KWES1B DIA 4.00 SQ 3.00 7/32" UNC	K11133144197	4.00	3.00
KWES1B DIA 4.50 SQ 3.40 1/4" UNC	K11133145159	4.50	3.40
KWES1B DIA 4.50 SQ 3.40 5/32" UNC	K11133145203	4.50	3.40
KWES1B DIA 7.00 SQ 5.50 1/4" UNC	K11133147159	7.00	5.50
KWES1B DIA 7.00 SQ 5.50 1/8" (BSPT)	K11133147204	7.00	5.50
KWES1B DIA 7.00 SQ 5.50 3/8" UNC	K11133147164	7.00	5.50
KWES1B DIA 8.00 SQ 6.20 1/8" G (BSPT)	K11133148242	8.00	6.20
KWES1B DIA 8.00 SQ 6.20 5/16" UNC	K11133148161	8.00	6.20
KWES1B DIA 8.00 SQ 6.20 7/16" UNC	K11133148162	8.00	6.20
KWES1B DIA 9.00 SQ 7.00 3/8" UNC	K11133149164	9.00	7.00
KWES1B DIA 9.00 SQ 7.00 1/2" UNC	K11133149163	9.00	7.00
KWES1B DIA 11.00 SQ 9.00 1/4" G(BSP)	K11133150205	11.00	9.00
KWES1B DIA 11.00 SQ 9.00 9/16" UNC	K11133150166	11.00	9.00

As per (JIS) Standards

KWES1B DIA 4.00 SQ 3.00 M3	K11133144104	4.00	3.00
KWES1B DIA 4.00 SQ 3.00 M3.5	K11133144106	4.00	3.00
KWES1B DIA 4.00 SQ 3.20 M3	K11133163104	4.00	3.20
KWES1B DIA 4.00 SQ 3.20 M4	K11133163105	4.00	3.20
KWES1B DIA 5.00 SQ 4.00 M4	K11133122105	5.00	4.00
KWES1B DIA 5.00 SQ 4.00 M4.5	K11133122107	5.00	4.00
KWES1B DIA 5.50 SQ 4.50 M5	K11133164108	5.50	4.50
KWES1B DIA 5.50 SQ 4.50 M5.5	K11133164141	5.50	4.50
KWES1B DIA 5.50 SQ 4.50 M7	K11133164110	5.50	4.50
KWES1B DIA 6.00 SQ 4.50 M6	K11133165109	6.00	4.50
KWES1B DIA 6.20 SQ 5.00 M7	K11133167110	6.20	5.00
KWES1B DIA 6.20 SQ 5.00 M8	K11133167111	6.20	5.00
KWES1B DIA 7.00 SQ 5.50 M9	K11133147142	7.00	5.50
KWES1B DIA 7.00 SQ 5.50 M10	K11133147112	7.00	5.50
KWES1B DIA 8.00 SQ 6.00 M11	K11133168143	8.00	6.00
KWES1B DIA 8.50 SQ 6.50 M12	K11133170113	8.50	6.50
KWES1B DIA 9.00 SQ 7.00 1/2" UNC	K11133149163	9.00	7.00
KWES1B DIA 10.50 SQ 8.00 M14	K11133172114	10.50	8.00
KWES1B DIA 10.50 SQ 8.00 M15	K11133172144	10.50	8.00
KWES1B DIA 11.00 SQ 9.00 1/4" G(BSP)	K11133150205	11.00	9.00

Note: All Dimensions are in mm
For DIN Standard Numbers and more technical details please see page number 281 - 284



As per (ANSI) (US) Standards

Item Name	Item Code	Dia	Square
KWES1B DIA 0.141" SQ 0.110" NO. 06UNC	K11133191155	0.141"	0.110"
KWES1B DIA 0.168" SQ 0.131" NO. 08UNC	K11133192156	0.168"	0.131"
KWES1B DIA 0.194" SQ 0.152" NO. 10UNC	K11133198157	0.194"	0.152"
KWES1B DIA 0.220" SQ 0.165" NO. 12UNC	K11133199158	0.220"	0.165"
KWES1B DIA 0.255" SQ 0.191" 1/4" UNC	K11133200159	0.255"	0191"
KWES1B DIA 0.312" SQ 0.234" 1/8" SS	K11133225160	0.312"	0.234"
KWES1B DIA 0.318" SQ 0.238" 5/16" UNC	K11133202161	0.318"	0.238"
KWES1B DIA 0.323" SQ 0.242" 7/16" UNC	K11133193162	0.323"	0.242"
KWES1B DIA 0.367" SQ 0.275" 1/2" UNC	K11133194163	0.367"	0.275"
KWES1B DIA 0.381" SQ 0.286" 3/8" UNC	K11133195164	0.381"	0.286"
KWES1B DIA 0.429" SQ 0.322" 1/4" NPT	K11133196248	0.429"	0.322"
KWES1B DIA 0.429" SQ 0.322" 9/16" UNC	K11133196166	0.429"	0.322"
KWES1B DIA 0.437" SQ 0.328 1/8" LS	K11133197165	0.437"	0.328"

Note: All Dimensions are in mm
For DIN Standard Numbers and more technical details please see page number 281 - 284

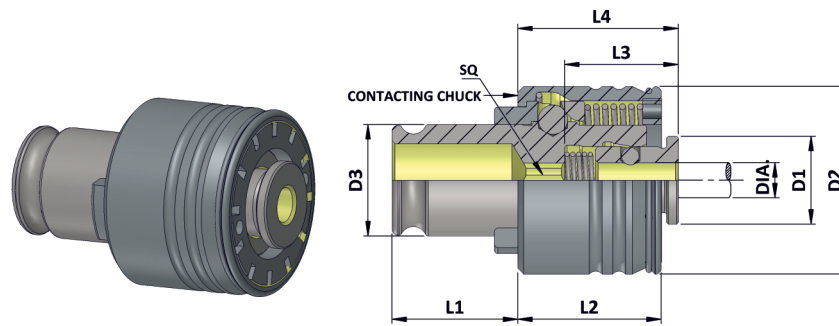

Technical Information

Item Name	Capacity	Shank Dia.	Suitable Chuck Size	D1	D2	D3	L1	L2	L3	L4
KWES 2 B	M8 - M20	6 - 18	2	30	50	31	35	31	30	34

As per (ISO) (529 -1975) Standards

Item Name	Item Code	Dia	Square
KWES2B DIA 6.30 SQ 5.00 M6	K11134124109	6.30	5.00
KWES2B DIA 6.30 SQ 5.00 M8	K11134124111	6.30	5.00
KWES2B DIA 7.10 SQ 5.60 M7	K11134125110	7.10	5.60
KWES2B DIA 7.10 SQ 5.60 M10	K11134125112	7.10	5.60
KWES2B DIA 8.00 SQ 6.30 M8	K11134126111	8.00	6.30
KWES2B DIA 8.00 SQ 6.30 M10	K11134126112	8.00	6.30
KWES2B DIA 9.00 SQ 7.10 M12	K11134127113	9.00	7.10
KWES2B DIA 10.00 SQ 8.00 M10	K11134128112	10.00	8.00
KWES2B DIA 10.00 SQ 8.00 M10	K11134128112	10.00	8.00
KWES2B DIA 10.00 SQ 8.00 M10	K11134128112	10.00	8.00
KWES2B DIA 14.00 SQ 11.20 M18	K11134131116	14.00	11.20
KWES2B DIA 14.00 SQ 11.20 M20	K11134131117	14.00	11.20
KWES2B DIA 16.00 SQ 12.50 M22	K11134132118	16.00	12.50
KWES2B DIA 18.00 SQ 14.00 M24	K11134133119	18.00	14.00
KWES2B DIA 6.30 SQ 5.00 1/4" UNC	K11134124159	6.30	5.00
KWES2B DIA 6.30 SQ 5.00 5/16" UNC	K11134124161	6.30	5.00
KWES2B DIA 7.10 SQ 5.60 3/8" UNC	K11134125164	7.10	5.60
KWES2B DIA 8.00 SQ 6.30 1/8" G(BSP)	K11134126204	8.00	6.30
KWES2B DIA 8.00 SQ 6.30 5/16" UNC	K11134126161	8.00	6.30
KWES2B DIA 8.00 SQ 6.30 7/16" UNC	K11134126162	8.00	6.30
KWES2B DIA 9.00 SQ 7.10 1/2" UNC	K11134127163	9.00	7.10
KWES2B DIA 10.00 SQ 8.00 1/4" G(BSP)	K11134128205	10.00	8.00
KWES2B DIA 10.00 SQ 8.00 3/8" UNC	K11134128164	10.00	8.00
KWES2B DIA 11.20 SQ 9.00 9/16" UNC	K11134129166	11.20	9.00
KWES2B DIA 12.50 SQ 10.00 3/8" G(BSP)	K11134130206	12.50	10.00
KWES2B DIA 12.50 SQ 10.00 5/8" UNC	K11134130168	12.50	10.00
KWES2B DIA 14.00 SQ 11.20 3/4" UNC	K11134131171	14.00	11.20
KWES2B DIA 16.00 SQ 12.50 1/12" G(BSP)	K11134132210	16.00	12.50
KWES2B DIA 16.00 SQ 12.50 7/8" UNC	K11134132174	16.00	12.50
KWES2B DIA 18.00 SQ 14.00 1/2" G(BSP)	K11134133210	18.00	14.00

Note: All Dimensions are in mm
For DIN Standard Numbers and more technical details please see page number 281 - 284



As per (DIN) Standards

Item Name	Item Code	Dia	Square
KWES2B DIA 6.00 SQ 4.90 M5	K11134146108	6.00	4.90
KWES2B DIA 6.00 SQ 4.90 M6	K11134146109	6.00	4.90
KWES2B DIA 6.00 SQ 4.90 M8	K11134146111	6.00	4.90
KWES2B DIA 7.00 SQ 5.50 M7	K11134147110	7.00	5.50
KWES2B DIA 7.00 SQ 5.50 M9	K11134147142	7.00	5.50
KWES2B DIA 7.00 SQ 5.50 M10	K11134147112	7.00	5.50
KWES2B DIA 8.00 SQ 6.20 M8	K11134148111	8.00	6.20
KWES2B DIA 8.00 SQ 6.20 M10	K11134148112	8.00	6.20
KWES2B DIA 8.00 SQ 6.20 M11	K11134148143	8.00	6.20
KWES2B DIA 9.00 SQ 7.00 M12	K11134149113	9.00	7.00
KWES2B DIA 11.00 SQ 9.00 M14	K11134150114	11.00	9.00
KWES2B DIA 12.00 SQ 9.00 M16	K11134151115	12.00	9.00
KWES2B DIA 14.00 SQ 11.00 M18	K11134152116	14.00	11.00
KWES2B DIA 16.00 SQ 12.00 M20	K11134153117	16.00	12.00
KWES2B DIA 18.00 SQ 14.50 M22	K11134154118	18.00	14.50
KWES2B DIA 18.00 SQ 14.50 M24	K11134154119	18.00	14.50
KWES2B DIA 7.00 SQ 5.50 1/4" UNC	K11134147159	7.00	5.50
KWES2B DIA 7.00 SQ 5.50 1/8" G(BSP)	K11134147204	7.00	5.50
KWES2B DIA 7.00 SQ 5.50 3/8" UNC	K11134147164	7.00	5.50
KWES2B DIA 8.00 SQ 6.20 1/8" (BSPT)	K11134148242	8.00	6.20
KWES2B DIA 8.00 SQ 6.20 5/16" UNC	K11134148161	8.00	6.20
KWES2B DIA 8.00 SQ 6.20 7/16" UNC	K11134148162	8.00	6.20
KWES2B DIA 9.00 SQ 7.00 1/2" UNC	K11134149163	9.00	7.00
KWES2B DIA 9.00 SQ 7.00 3/8" UNC	K11134149164	9.00	7.00
KWES2B DIA 11.00 SQ 9.00 1/4" G(BSP)	K11134150205	11.00	9.00
KWES2B DIA 11.00 SQ 9.00 9/16" UNC	K11134150166	11.00	9.00
KWES2B DIA 12.00 SQ 9.00 3/8" G(BSP)	K11134151206	12.00	9.00
KWES2B DIA 12.00 SQ 9.00 5/8" UNC	K11134151168	12.00	9.00
KWES2B DIA 14.00 SQ 11.00 11/16" UNC	K11134152169	14.00	11.00
KWES2B DIA 14.00 SQ 11.00 Pg11	K11134152257	14.00	11.00
KWES2B DIA 16.00 SQ 12.00 1/2" G(BSP)	K11134153210	16.00	12.00
KWES2B DIA 16.00 SQ 12.00 1/4" G(BSP)	K11134153205	16.00	12.00
KWES2B DIA 16.00 SQ 12.00 13/16" UNC	K11134153172	16.00	12.00
KWES2B DIA 18.00 SQ 14.50 15/16" UNC	K11134154177	18.00	14.50
KWES2B DIA 18.00 SQ 14.50 5/8" G(BSP)	K11134154208	18.00	14.50
KWES2B DIA 18.00 SQ 14.50 7/8" UNC	K11134154174	18.00	14.50

Note: All Dimensions are in mm
For DIN Standard Numbers and more technical details please see page number 281 - 284

Continued...



As per (JIS) Standards

Item Name	Item Code	Dia	Square
KWES2B DIA 6.00 SQ 4.50 M6	K11134165109	6.00	4.50
KWES2B DIA 6.20 SQ 5.00 M7	K11134167110	6.20	5.00
KWES2B DIA 6.20 SQ 5.00 M8	K11134167111	6.20	5.00
KWES2B DIA 7.00 SQ 5.50 M9	K11134147142	7.00	5.50
KWES2B DIA 7.00 SQ 5.50 M10	K11134147112	7.00	5.50
KWES2B DIA 8.00 SQ 6.00 M11	K11134168143	8.00	6.00
KWES2B DIA 8.00 SQ 6.00 1/8" G(BSP)	K11134168204	8.00	6.00
KWES2B DIA 8.00 SQ 6.20 M11	K11134148143	8.00	6.20
KWES2B DIA 8.50 SQ 6.50 M12	K11134170113	8.50	6.50
KWES2B DIA 9.00 SQ 7.00 1/2" UNC	K11134149163	9.00	7.00
KWES2B DIA 10.50 SQ 8.00 M14	K11134172114	10.50	8.00
KWES2B DIA 10.50 SQ 8.00 M15	K11134172144	10.50	8.00
KWES2B DIA 11.00 SQ 9.00 1/4" G(BSP)	K11134150205	11.00	9.00
KWES2B DIA 12.00 SQ 9.00 5/8" UNC	K11134151168	12.00	9.00
KWES2B DIA 12.50 SQ 10.00 M16	K11134130115	12.50	10.00
KWES2B DIA 13.00 SQ 10.00 M17	K11134173145	13.00	10.00
KWES2B DIA 14.00 SQ 11.00 M18	K11134152116	14.00	11.00
KWES2B DIA 15.00 SQ 12.00 M20	K11134174117	15.00	12.00
KWES2B DIA 17.00 SQ 13.00 M22	K11134175118	17.00	13.00
KWES2B DIA 19.00 SQ 15.00 M24	K11134176119	19.00	15.00

As per (ANSI) (US) Standards

KWES2B DIA 0.255" SQ 0.191" 1/4" UNC	K11134200159	0.255"	0.191"
KWES2B DIA 0.312" SQ 0.234" 1/8" PSS	K11134225160	0.312"	0.234"
KWES2B DIA 0.318" SQ 0.238" 5/16" UNC	K11134202161	0.318"	0.238"
KWES2B DIA 0.323" SQ 0.242" 7/16" UNC	K11134193162	0.323"	0.242"
KWES2B DIA 0.367" SQ 0.275" 1/2" UNC	K11134194163	0.367"	0.275"
KWES2B DIA 0.381" SQ 0.286" 3/8" UNC	K11134195164	0.381"	0.286"
KWES2B DIA 0.429" SQ 0.322" 1/4" G(BSP)	K11134196205	0.429"	0.322"
KWES2B DIA 0.429" SQ 0.322" 1/4" NPT	K11134196248	0.429"	0.322"
KWES2B DIA 0.429" SQ 0.322" 9/16" UNC	K11134196166	0.429"	0.322"
KWES2B DIA 0.437" SQ 0.328" 1/8" PLS	K11134197167	0.437"	0.328"
KWES2B DIA 0.480" SQ 0.360" 5/8" UNC	K11134203168	0.480"	0.360"
KWES2B DIA 0.542" SQ 0.406" 11/16" UNC	K11134204169	0.542"	0.406"
KWES2B DIA 0.542" SQ 0.406" 3/8" NPT	K11134259243	0.542"	0.406"
KWES2B DIA 0.562" SQ 0.421" 1/4" P	K11134205170	0.562"	0.421"
KWES2B DIA 0.590" SQ 0.442" 3/4" UNC	K11134206171	0.590"	0.442"
KWES2B DIA 0.590" SQ 0.442" 3/4" UNC TC	K11134206252	0.590"	0.442"
KWES2B DIA 0.652" SQ 0.489" 13/16" UNC	K11134207172	0.652"	0.489"
KWES2B DIA 0.687" SQ 0.515" 1/2" P	K11134208173	0.687"	0.515"
KWES2B DIA 0.687" SQ 0.515" 5/8" G(BSP)	K11134208208	0.687"	0.515"
KWES2B DIA 0.697" SQ 0.523" 7/8" UNC	K11134209174	0.697"	0.523"
KWES2B DIA 0.700" SQ 0.531" 3/8" P	K11134210175	0.700"	0.531"

Note: All Dimensions are in mm
For DIN Standard Numbers and more technical details please see page number 281 - 284

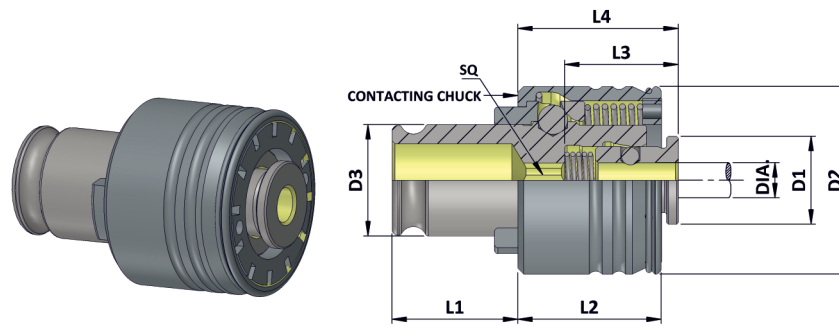

Technical Information

Item Name	Capacity	Shank Dia.	Suitable Chuck Size	D1	D2	D3	L1	L2	L3	L4
KWES 3 B	M14 - M33	11 - 28	3	48	72	48	55.5	41	44	45

As per (ISO) (529 -1975) Standards

Item Name	Item Code	Dia	Square
KWES3B DIA 11.20 SQ 9.00 M14	K11135129114	11.20	9.00
KWES3B DIA 12.50 SQ 10.00 M16	K11135130115	12.50	10.00
KWES3B DIA 14.00 SQ 11.20 M18	K11135131116	14.00	11.20
KWES3B DIA 14.00 SQ 11.20 M20	K11135131117	14.00	11.20
KWES3B DIA 16.00 SQ 12.50 M22	K11135132118	16.00	12.50
KWES3B DIA 18.00 SQ 14.00 M24	K11135133119	18.00	14.00
KWES3B DIA 20.00 SQ 16.00 M27	K11135134122	20.00	16.00
KWES3B DIA 20.00 SQ 16.00 M30	K11135134123	20.00	16.00
KWES3B DIA 22.40 SQ 18.00 M33	K11135135124	22.40	18.00
KWES3B DIA 25.00 SQ 20.00 M36	K11135136125	25.00	20.00
KWES3B DIA 28.00 SQ 22.40 M39 (FINE PITCH)	K11135137126	28.00	22.40
KWES3B DIA 28.00 SQ 22.40 M42 (FINE PITCH)	K11135137127	28.00	22.40
KWES3B DIA 11.20 SQ 9.00 9/16" UNC	K11135129166	11.20	9.00
KWES3B DIA 12.50 SQ 10.00 5/8" UNC	K11135130168	12.50	10.00
KWES3B DIA 14.00 SQ 11.20 11/16" UNC	K11135131169	14.00	11.20
KWES3B DIA 14.00 SQ 11.20 3/4" UNC	K11135131171	14.00	11.20
KWES3B DIA 16.00 SQ 12.50 7/8" UNC	K11135132174	16.00	12.50
KWES3B DIA 18.00 SQ 14.00 1" UNC	K11135133178	18.00	14.00
KWES3B DIA 20.00 SQ 16.00 1-1/8" UNC	K11135134179	20.00	16.00
KWES3B DIA 22.40 SQ 18.00 1-1/4" UNC	K11135135181	22.40	18.00
KWES3B DIA 25.00 SQ 20.00 1-3/8" UNC	K11135136182	25.00	20.00

Note: All Dimensions are in mm
For DIN Standard Numbers and more technical details please see page number 281 - 284

Continued...



As per (DIN) Standards

Item Name	Item Code	Dia	Square
KWES3B DIA 11.00 SQ 9.00 M14	K11135150114	11.00	9.00
KWES3B DIA 12.00 SQ 9.00 M16	K11135151115	12.00	9.00
KWES3B DIA 14.00 SQ 11.00 M18	K11135152116	14.00	14.00
KWES3B DIA 16.00 SQ 12.00 M20	K11135153117	16.00	12.00
KWES3B DIA 18.00 SQ 14.50 M22	K11135154118	18.00	14.50
KWES3B DIA 18.00 SQ 14.50 M24	K11135154119	18.00	14.50
KWES3B DIA 20.00 SQ 16.00 M27	K11135134122	20.00	16.00
KWES3B DIA 22.00 SQ 18.00 M30	K11135155123	22.00	18.00
KWES3B DIA 25.00 SQ 20.00 M33	K11135136124	25.00	20.00
KWES3B DIA 28.00 SQ 22.00 M36	K11135156125	28.00	22.00
KWES3B DIA 11.00 SQ 9.00 1/4" BSPT	K11135150255	11.00	9.00
KWES3B DIA 11.00 SQ 9.00 3/8" BSPT	K11135150256	11.00	9.00
KWES3B DIA 11.00 SQ 9.00 9/16" UNC	K11135150166	11.00	9.00
KWES3B DIA 12.00 SQ 9.00 3/8" BSPT	K11135151256	12.00	9.00
KWES3B DIA 12.00 SQ 9.00 5/8" UNC	K11135151168	12.00	9.00
KWES3B DIA 14.00 SQ 11.00 11/16" UNC	K11135152169	14.00	11.00
KWES3B DIA 16.00 SQ 12.00 1/2" G(BSP)	K11135153210	16.00	12.00
KWES3B DIA 16.00 SQ 12.00 13/16" UNC	K11135153172	16.00	12.00
KWES3B DIA 18.00 SQ 14.50 15/16" UNC	K11135154177	18.00	14.50
KWES3B DIA 18.00 SQ 14.50 5/8" G(BSP)	K11135154208	18.00	14.50
KWES3B DIA 18.00 SQ 14.50 7/8" UNC	K11135154174	18.00	14.50
KWES3B DIA 20.00 SQ 16.00 1" UNC	K11135134178	20.00	16.00
KWES3B DIA 20.00 SQ 16.00 3/4" G(BSP)	K11135134209	20.00	16.00
KWES3B DIA 22.00 SQ 18.00 1-1/8" UNC	K11135155179	22.00	18.00
KWES3B DIA 22.00 SQ 18.00 7/8" G(BSP)	K11135155211	22.00	18.00
KWES3B DIA 25.00 SQ 20.00 1" G(BSP)	K11135136212	25.00	20.00
KWES3B DIA 25.00 SQ 20.00 1-1/4" UNC	K11135136181	25.00	20.00
KWES3B DIA 28.00 SQ 22.00 1-1/8" G(BSP)	K11135156213	28.00	22.00
KWES3B DIA 28.00 SQ 22.00 1-3/8" UNC	K11135156182	28.00	22.00

Note: All Dimensions are in mm
For DIN Standard Numbers and more technical details please see page number 281 - 284



As per (JIS) Standards

Item Name	Item Code	Dia	Square
KWES3B DIA 12.50 SQ 10.00 M16	K11135130115	12.50	10.00
KWES3B DIA 13.00 SQ 10.00 M17	K11135173145	13.00	10.00
KWES3B DIA 14.00 SQ 11.00 M18	K11135152116	14.00	11.00
KWES3B DIA 15.00 SQ 12.00 M20	K11135174117	15.00	12.00
KWES3B DIA 17.00 SQ 13.00 M22	K11135175118	17.00	13.00
KWES3B DIA 19.00 SQ 15.00 M24	K11135176119	19.00	15.00
KWES3B DIA 19.00 SQ 15.00 M25	K11135176147	19.00	15.00
KWES3B DIA 20.00 SQ 15.00 M26	K11135177148	20.00	15.00
KWES3B DIA 20.00 SQ 15.00 M27	K11135177122	20.00	15.00
KWES3B DIA 21.00 SQ 17.00 M28	K11135178149	21.00	17.00
KWES3B DIA 23.00 SQ 17.00 M30	K11135180123	23.00	17.00
KWES3B DIA 24.00 SQ 19.00 M32	K11135181150	24.00	19.00
KWES3B DIA 25.00 SQ 19.00 M33	K11135186124	25.00	19.00
KWES3B DIA 26.00 SQ 21.00 M34	K11135182151	26.00	21.00
KWES3B DIA 26.00 SQ 21.00 M35	K11135182152	26.00	21.00
KWES3B DIA 28.00 SQ 21.00 M36	K11135187125	28.00	21.00
KWES3B DIA 28.00 SQ 21.00 M38	K11135187153	28.00	21.00
KWES3B DIA 30.00 SQ 23.00 M39	K11135183138	30.00	23.00
KWES3B DIA 30.00 SQ 23.00 M40	K11135183154	30.00	23.00
KWES3B DIA 11.00 SQ 9.00 1/4" BSPT	K11135150255	11.00	9.00
KWES3B DIA 12.00 SQ 9.00 5/8" UNC	K11135151168	12.00	9.00

As per (ANSI) (US) Standards

KWES3B DIA 0.652" SQ 0.489" 13/16" UNC	K11135207176	0.652"	0.489"
KWES3B DIA 0.687" SQ 0.515" 1/2" G(BSP)	K11135208210	0.687"	0.515"
KWES3B DIA 0.687" SQ 0.515" 1/2" P	K11135208173	0.687"	0.515"
KWES3B DIA 0.697" SQ 0.523" 7/8" UNC	K11135209174	0.697"	0.523"
KWES3B DIA 0.700" SQ 0.531" 3/8" P	K11135210175	0.700"	0.531"
KWES3B DIA 0.760" SQ 0.570" 15/16" UNC	K11135211177	0.760"	0.570"
KWES3B DIA 0.800" SQ 0.600" 1" UNC	K11135212178	0.800"	0.600"
KWES3B DIA 0.896" SQ 0.672" 1-1/8" UNC	K11135213179	0.896"	0.672"
KWES3B DIA 0.906" SQ 0.679" 3/4" P	K11135214180	0.906"	0.679"
KWES3B DIA 1.021" SQ 0.766" 1-1/4" UNC	K11135215181	1.021"	0.766"
KWES3B DIA 1.108" SQ 0.831" 1-3/8" UNC	K11135216182	1.108"	0.831"
KWES3B DIA 1.125" SQ 0.843" 1" P	K11135217183	1.125"	0.843"

Note: All Dimensions are in mm
For DIN Standard Numbers and more technical details please see page number 281 - 284

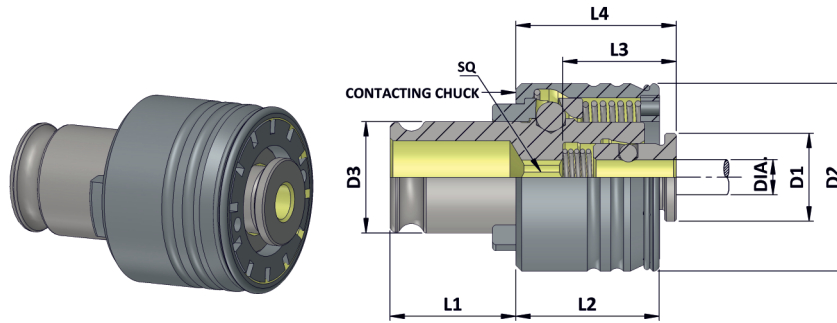

Technical Information

Item Name	Capacity	Shank Dia.	Suitable Chuck Size	D1	D2	D3	L1	L2	L3	L4
KWES 4 B	M22 - M48	18 - 36	4	60	95	60	63	61	71	68

As per (ISO) (529 -1975) Standards

Item Name	Item Code	Dia	Square
KWES4B DIA 16.00 SQ 12.50 M22	K11136132118	16.00	12.50
KWES4B DIA 18.00 SQ 14.00 M24	K11136133119	18.00	14.00
KWES4B DIA 20.00 SQ 16.00 M27	K11136134122	20.00	16.00
KWES4B DIA 20.00 SQ 16.00 M30	K11136134123	20.00	16.00
KWES4B DIA 22.40 SQ 18.00 M33	K11136135124	22.40	18.00
KWES4B DIA 25.00 SQ 20.00 M36	K11136136125	25.00	20.00
KWES4B DIA 28.00 SQ 22.40 M39	K11136137138	28.00	22.40
KWES4B DIA 28.00 SQ 22.40 M42	K11136137129	28.00	22.40
KWES4B DIA 31.50 SQ 25.00 M45	K11136138130	31.50	25.00
KWES4B DIA 31.50 SQ 25.00 M48	K11136138131	31.50	25.00
KWES4B DIA 35.50 SQ 28.00 M52 (FINE PITCH)	K11136139132	35.50	28.00
KWES4B DIA 35.50 SQ 28.00 M56 (FINE PITCH)	K11136139133	35.50	28.00
KWES4B DIA 16.00 SQ 12.50 7/8" UNC	K11136132174	16.00	12.50
KWES4B DIA 18.00 SQ 14.00 1" UNC	K11136133178	18.00	14.00
KWES4B DIA 20.00 SQ 16.00 1-1/8" UNC	K11136134179	20.00	16.00
KWES4B DIA 22.40 SQ 18.00 1-1/4" UNC	K11136135181	22.40	18.00
KWES4B DIA 25.00 SQ 20.00 1-3/8" UNC	K11136136182	25.00	20.00
KWES4B DIA 28.00 SQ 22.40 1-1/2" UNC	K11136137184	28.00	22.40
KWES4B DIA 31.50 SQ 25.00 1-3/4" UNC	K11136138186	31.50	25.00
KWES4B DIA 35.50 SQ 28.00 2" UNC	K11136139198	35.50	28.00

Note: All Dimensions are in mm
For DIN Standard Numbers and more technical details please see page number 281 - 284



As per (DIN) Standards

Item Name	Item Code	Dia	Square
KWES4B DIA 18.00 SQ 14.50 M22	K11136154118	18.00	14.50
KWES4B DIA 18.00 SQ 14.50 M24	K11136154119	18.00	14.50
KWES4B DIA 20.00 SQ 16.00 M27	K11136134122	20.00	16.00
KWES4B DIA 22.00 SQ 18.00 M30	K11136155123	22.00	18.00
KWES4B DIA 25.00 SQ 20.00 M33	K11136136124	25.00	20.00
KWES4B DIA 28.00 SQ 22.00 M36	K11136156125	28.00	22.00
KWES4B DIA 32.00 SQ 24.00 M39	K11136157138	32.00	24.00
KWES4B DIA 32.00 SQ 24.00 M42	K11136157129	32.00	24.00
KWES4B DIA 32.00 SQ 24.00 M45	K11136157130	32.00	24.00
KWES4B DIA 36.00 SQ 29.00 M45	K11136158130	36.00	29.00
KWES4B DIA 36.00 SQ 29.00 M48	K11136158131	36.00	29.00
KWES4B DIA 18.00 SQ 14.50 1/2" NPT	K11136154253	18.00	14.50
KWES4B DIA 18.00 SQ 14.50 15/16" UNC	K11136154177	18.00	14.50
KWES4B DIA 18.00 SQ 14.50 3/8 " NPT	K11136154243	18.00	14.50
KWES4B DIA 18.00 SQ 14.50 5/8" G(BSP)	K11136154208	18.00	14.50
KWES4B DIA 18.00 SQ 14.50 7/8" UNC	K11136154174	18.00	14.50
KWES4B DIA 20.00 SQ 16.00 1" UNC	K11136134178	20.00	16.00
KWES4B DIA 20.00 SQ 16.00 3/4" G(BSP)	K11136134209	20.00	16.00
KWES4B DIA 22.00 SQ 18.00 1-1/8" UNC	K11136155179	22.00	18.00
KWES4B DIA 22.00 SQ 18.00 7/8" G(BSP)	K11136155211	22.00	18.00
KWES4B DIA 25.00 SQ 20.00 1" G(BSP)	K11136136212	25.00	20.00
KWES4B DIA 25.00 SQ 20.00 1-1/4" UNC	K11136136181	25.00	20.00
KWES4B DIA 28.00 SQ 22.00 1-1/8" G(BSP)	K11136156213	28.00	22.00
KWES4B DIA 28.00 SQ 22.00 1-3/8" UNC	K11136156182	28.00	22.00
KWES4B DIA 32.00 SQ 24.00 1-1/2" UNC	K11136157184	32.00	24.00
KWES4B DIA 32.00 SQ 24.00 1-1/4" G(BSP)	K11136157214	32.00	24.00
KWES4B DIA 32.00 SQ 24.00 1-5/8" UNC	K11136157219	32.00	24.00
KWES4B DIA 36.00 SQ 29.00 1-1/2" G(BSP)	K11136158216	36.00	29.00
KWES4B DIA 36.00 SQ 29.00 1-3/4" G(BSP)	K11136158217	36.00	29.00
KWES4B DIA 36.00 SQ 29.00 1-3/4" UNC	K11136158186	36.00	29.00
KWES4B DIA 36.00 SQ 29.00 1-3/8" G(BSP)	K11136158215	36.00	29.00
KWES4B DIA 36.00 SQ 29.00 1-7/8" UNC	K11136158220	36.00	29.00
KWES4B DIA 36.00 SQ 29.00 2" G(BSP)	K11136158218	36.00	29.00

Note: All Dimensions are in mm
For DIN Standard Numbers and more technical details please see page number 281 - 284

Continued...



As per (JIS) Standards

Item Name	Item Code	Dia	Square
KWES4B DIA 17.00 SQ 13.00 M22	K11136175118	17.00	13.00
KWES4B DIA 19.00 SQ 15.00 M24	K11136176119	19.00	15.00
KWES4B DIA 19.00 SQ 15.00 M25	K11136176147	19.00	15.00
KWES4B DIA 20.00 SQ 15.00 M26	K11136177148	20.00	15.00
KWES4B DIA 20.00 SQ 15.00 M27	K11136177122	20.00	15.00
KWES4B DIA 21.00 SQ 17.00 M28	K11136178149	21.00	17.00
KWES4B DIA 23.00 SQ 17.00 M30	K11136180123	23.00	17.00
KWES4B DIA 24.00 SQ 19.00 M32	K11136181150	24.00	19.00
KWES4B DIA 25.00 SQ 19.00 M33	K11136186124	25.00	19.00
KWES4B DIA 26.00 SQ 21.00 M34	K11136182151	26.00	21.00
KWES4B DIA 26.00 SQ 21.00 M35	K11136182152	26.00	21.00
KWES4B DIA 28.00 SQ 21.00 M36	K11136187125	28.00	21.00
KWES4B DIA 28.00 SQ 21.00 M38	K11136187153	28.00	21.00
KWES4B DIA 30.00 SQ 23.00 M39	K11136183138	30.00	23.00
KWES4B DIA 30.00 SQ 23.00 M40	K11136183154	30.00	23.00
KWES4B DIA 32.00 SQ 26.00 M42	K11136184129	32.00	26.00
KWES4B DIA 35.00 SQ 26.00 M45	K11136185130	35.00	26.00
KWES4B DIA 38.00 SQ 29.00 M48	K11136188131	38.00	29.00

As per (ANSI) (US) Standards

KWES4B DIA 0.800" SQ 0.600" 1" UNC	K11136212178	0.800"	0.600"
KWES4B DIA 0.896" SQ 0.672" 1-1/8" UNC	K11136213179	0.896"	0.672"
KWES4B DIA 0.906" SQ 0.679" 3/4" P	K11136214180	0.906"	0.679"
KWES4B DIA 1.021" SQ 0.766" 1-1/4" UNC	K11136215181	1.021"	0.766"
KWES4B DIA 1.108" SQ 0.831" 1-3/8" UNC	K11136216182	1.108"	0.831"
KWES4B DIA 1.125" SQ 0.843" 1" P	K11136217183	1.125"	0.843"
KWES4B DIA 1.233" SQ 0.925" 1-1/2" UNC	K11136218184	1.233"	0.925"
KWES4B DIA 1.312" SQ 0.984" 1-1/4" P	K11136219185	1.312"	0.984"
KWES4B DIA 1.430" SQ 1.072" 1-3/4" UNC	K11136221186	1.430"	1.072"
KWES4B DIA 1.500" SQ 1.125" 1-1/2" P	K11136222187	1.500"	1.125"

Note: All Dimensions are in mm
For DIN Standard Numbers and more technical details please see page number 281 - 284



Quick Change Tap Adaptor With Safety Clutch (KWESK../B)

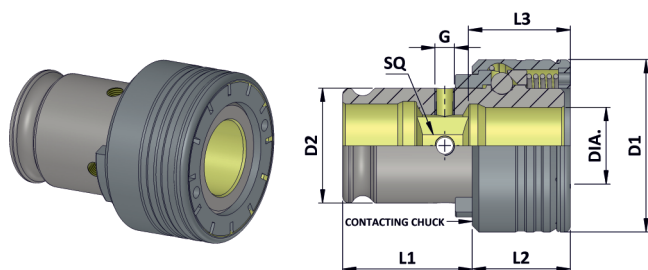

Accessories for
Precision Tool Holders

Technical Information

Item Name	Capacity	Shank Dia.	Suitable Chuck Size	D1	D2	L1	L2	L3
KWESK 1B	M16	> 11.2 - 12	1	32	19	21.5	25	27.5
KWESK 2B	M27 - M30	> 18 - 22	2	50	31	35	31	32.5
KWESK 3B	M39 - M48	> 28 - 36	3	72	48	55.5	41	40
KWESK 4B	M52 - M60	> 36 - 45	4	95	60	63	61	54

Note: All Dimensions are in mm

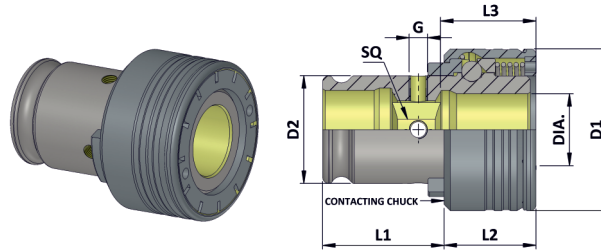

KWESK1B Tap Adaptor

Item Name	Capacity	Shank Dia.	Suitable Chuck Size	D1	D2	L1	L2	L3
KWESK 1B	M16	> 11.2 - 12	1	32	19	21.5	25	27.5

Item Name	Item Code	Dia	Square
KWESK1B DIA 12.00 SQ 9.00 3/8" G(BSP)	K11232151206	12.00	9.00
KWESK1B DIA 12.00 SQ 9.00 M16 (FINE PITCH)	K11232151115	12.00	9.00

KWESK2B Tap Adaptor

Item Name	Capacity	Shank Dia.	Suitable Chuck Size	D1	D2	L1	L2	L3
KWESK 2B	M27 - M30	> 18 - 22	2	50	31	35	31	32.5

Item Name	Item Code	Dia	Square
KWESK2B DIA 19.00 SQ 15.00 M25 (FINE PITCH)	K11134176146	19.00	15.00
KWESK2B DIA 20.00 SQ 15.00 M26 (FINE PITCH)	K11134177195	20.00	15.00
KWESK2B DIA 20.00 SQ 15.00 M27 (FINE PITCH)	K11134177120	20.00	15.00
KWESK2B DIA 20.00 SQ 16.00 3/4" G(BSP)	K11231134209	20.00	16.00
KWESK2B DIA 20.00 SQ 16.00 M27 (FINE PITCH)	K11134134120	20.00	16.00
KWESK2B DIA 20.00 SQ 16.00 M30 (FINE PITCH)	K11134134121	20.00	16.00
KWESK2B DIA 22.00 SQ 18.00 M30 (FINE PITCH)	K11231155123	22.00	18.00

Note: All Dimensions are in mm
For DIN Standard Numbers and more technical details please see page number 281 - 284



KWESK3B Tap Adaptor

Item Name	Capacity	Shank Dia.	Suitable Chuck Size	D1	D2	L1	L2	L3
KWESK 3B	M39 - M48	> 28 - 36	3	72	48	55.5	41	40

Item Name	Item Code	Dia	Square
KWESK3B DIA 31.50 SQ 25.00 M36	K11135138125	31.50	25.00
KWESK3B DIA 31.50 SQ 25.00 M44 (FINE PITCH)	K11135138128	31.50	25.00
KWESK3B DIA 31.50 SQ 25.00 M48 (FINE PITCH)	K11135138140	31.50	25.00
KWESK3B DIA 32.00 SQ 24.00 1-1/4" G(BSP)	K11135157214	32.00	24.00
KWESK3B DIA 32.00 SQ 24.00 M39	K11135157138	32.00	24.00
KWESK3B DIA 32.00 SQ 24.00 M42	K11240157129	32.00	24.00
KWESK3B DIA 32.00 SQ 26.00 M42 (FINE PITCH)	K11135184129	32.00	26.00
KWESK3B DIA 35.00 SQ 26.00 M45 (FINE PITCH)	K11135185139	35.00	26.00
KWESK3B DIA 36.00 SQ 29.00 1-1/2" G(BSP)	K11135158216	36.00	29.00
KWESK3B DIA 36.00 SQ 29.00 1-3/4" G(BSP)	K11135158217	36.00	29.00
KWESK3B DIA 36.00 SQ 29.00 1-3/8" G(BSP)	K11135158215	36.00	29.00
KWESK3B DIA 36.00 SQ 29.00 2" G(BSP)	K11135158218	36.00	29.00
KWESK3B DIA 36.00 SQ 29.00 M45 (FINE PITCH)	K11135158139	36.00	29.00
KWESK3B DIA 36.00 SQ 29.00 M48 (FINE PITCH)	K11135158140	36.00	29.00
KWESK3B DIA 38.00 SQ 29.00 M48 (FINE PITCH)	K11135188140	38.00	29.00

KWESK4B Tap Adaptor

Item Name	Capacity	Shank Dia.	Suitable Chuck Size	D1	D2	L1	L2	L3
KWESK 4B	M52 - M60	> 36 - 45	4	95	60	63	61	54

Item Name	Item Code	Dia	Square
KWESK4B DIA 40.00 SQ 31.50 2-1/2" UNC	K11136220200	40.00	31.50
KWESK4B DIA 40.00 SQ 31.50 2-1/4" UNC	K11136220199	40.00	31.50
KWESK4B DIA 40.00 SQ 31.50 M60 (FINE PITCH)	K11136220134	40.00	31.50
KWESK4B DIA 40.00 SQ 32.00 1-7/8" UNC	K11136160220	40.00	32.00
KWESK4B DIA 40.00 SQ 32.00 2-1/4" G(BSP)	K11136160221	40.00	32.00
KWESK4B DIA 40.00 SQ 32.00 M52 (FINE PITCH)	K11136160132	40.00	32.00
KWESK4B DIA 40.00 SQ 32.00 M56 (FINE PITCH)	K11230160232	40.00	32.00
KWESK4B DIA 40.00 SQ 32.00 2" UNC	K11136160198	40.00	32.00
KWESK4B DIA 45.00 SQ 35.00 2-1/2" G(BSP)	K11136161222	45.00	35.00
KWESK4B DIA 45.00 SQ 35.00 2-1/4" UNC	K11136161199	45.00	35.00
KWESK4B DIA 45.00 SQ 35.00 M56 (FINE PITCH)	K11136161133	45.00	35.00
KWESK4B DIA 45.00 SQ 35.00 M60 (FINE PITCH)	K11136161134	45.00	35.00

Note: All Dimensions are in mm
For DIN Standard Numbers and more technical details please see page number 281 - 284

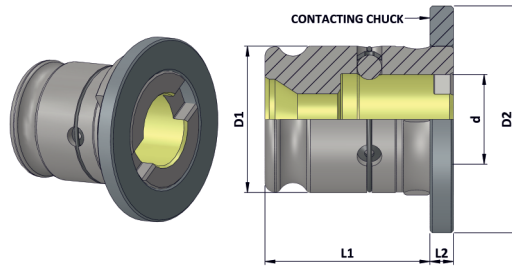

Reduction Socket (KWRE)

Item Name	Item Code	Suitable Chuck Size	Adaptor Size	d	D1	D2	L1	L2
KWRE 1/0	K11219254193	1	0	13	19	30	21.5	4
KWRE 2/1	K11219249193	2	1	19	31	48	35	5
KWRE 3/1	K11219250193	3	1	19	48	70	55.5	6
KWRE 3/2	K11219251193	3	2	31	48	70	55.5	6
KWRE 4/2	K11219252193	4	2	31	60	92	63	13
KWRE 4/3	K11219253193	4	3	48	60	92	63	13

Note: All Dimensions are in mm

Tap Shank Dimensions ISO 529 - 1975

Dimension Dia. x Square	Metric		UNC		UNF		BSW		BSF		BA	
		Shank dia. enlarged		Shank dia. enlarged		Shank dia. enlarged		Shank dia. enlarged		Shank dia. enlarged		Shank dia. enlarged
3.15 x 2.5	M4	M3	-	No. 4-40	-	No. 4-48	-	-	-	-	-	No. 5
	-	-	No. 8-32	No. 5-40	No. 8-36	No. 5-44	-	-	-	-	No. 3	-
3.55 x 2.8	M 4.5	M 3.5	No. 10-24	No. 6-32	No. 10-32	No. 6-40	3/16"-24	-	3/16"-32	-	No. 2	No. 4
4 x 3.15	M 5	M 4	No. 12-24	-	No. 12-28	-	-	-	7/32"-28	-	No. 1	-
4.5 x 3.55	M 6	-	1/4"-20	No. 8-32	1/4"-28	No. 3-36	1/4"-20	-	1/4"-26	-	No. 0	No. 3
5 x 4	-	M 5	-	No. 10-24	-	No. 10-32	-	3/16"-24	-	3/16"-32	-	No. 2
5.6 x 4.5	-	-	-	No. 12-24	-	No. 12-28	-	-	9/32"-26	7/32"-28	-	No. 1
6.3 x 5	M 8	M 6	5/16"-18	1/4"-20	5/16"-24	1/4"-28	5/16"-18	1/4"-20	5/16"-22	1/4"-26	-	No. 0
7.1 x 5.6	-	-	3/8"-16	-	3/8"-24	-	3/8"-16	-	3/8"-20	9/32"-36	-	-
8 x 6.3	M 10	M 8	7/16"-14	5/16"-18	7/16"-20	-	7/16"-14	5/16"-18	7/16"-18	5/16"-22	-	-
9 x 7.1	M 12	-	1/2"-13	-	1/2"-20	-	1/2"-12	-	1/2"-12	-	-	-
10 x 8	-	M 10	-	3/8"-16	-	3/8"-24	-	3/8"-16	-	3/8"-20	-	-
11.2 x 9	M 14	-	9/16"-12	-	9/16"-18	-	9/16"-12	-	9/16"-16	-	-	-
12.5 x 10	M 16	-	5/8"-11	-	5/8"-18	-	5/8"-11	-	3/8"-14	-	-	-
14 x 11.2	M 18	-	3/4"-10	-	3/4"-16	-	11/16"-11	-	11/16"-14	-	-	-
	M 20	-	-	-	-	-	3/4"-10	-	3/4"-12	-	-	-
16 x 12.5	M 22	-	7/8"-9	-	7/8"-14	-	7/8"-9	-	7/8"-11	-	-	-
18 x 14	M 24	-	1"-8	-	1"-12	-	1"-8	-	1"-10	-	-	-
20 x 16	M 27	-	1 1/8"-7	-	1 1/8"-12	-	1 1/8"-7	-	1 1/8"-9	-	-	-
	M 30	-	-	-	-	-	-	-	-	-	-	-
22.4 x 18	M 33	-	1 1/4"-4	-	1 1/4"-12	-	1 1/4"-7	-	1 1/4"-9	-	-	-
25 X 20	M 36	-	1 3/8"-6	-	1 3/8"-12	-	-	-	1 3/8"-8	-	-	-
28 x 22.4	M 39	-	1 1/2"-6	-	1 1/2"-12	-	1 1/2"-6	-	1 1/2"-8	-	-	-
	M 42	-	-	-	-	-	-	-	1 5/8"-8	-	-	-
31.5 x 25	M 45	-	1 3/4"-5	-	-	-	1 3/4"-5	-	1 3/4"-7	-	-	-
	M 48	-	-	-	-	-	-	-	-	-	-	-

Tap Shank Dimensions DIN Standards

Dimension Dia. x Square	DIN 352	DIN 353	DIN 371	DIN 374	DIN 376	DIN 2182	DIN 2183
3.5 x 2.7	M 3	-	M 3	M 5	M 5	1/8"	-
4 x 3	M 4	-	M 3.5	-	-	-	-
4.5 x 3.4	M 4	-	M 4	M 6	M 6	5/32"	1/4"
6 x 4.9	M 5	-	M 5	-	-	7/32"	-
	M 6	-	M 6	-	-	-	-
	M 8	-	-	M 8	M 8	-	-
7 x 5.5	M 10	G 1/8"	-	M 10	M 10	1/4"	3/8"
8 x 6.2	-	-	M 8	-	-	5/16"	7/16"
9 x 7	M 12	-	-	M 12	M 12	3/8"	1/2"
10 x 8	-	-	M 10	-	-	-	-
11 x 9	M 14	G 1/4"	-	M 14	M 14	-	9/16"
12 X 9	M 16	G 3/8"	-	M 16	M 16	-	5/8"
14 X 11	M 18	-	-	M 18	M 18	-	11/16"
16 X 12	M 20	G 1/2"	-	M 20	M 20	-	13/16"
18 x 14.5	M 22	G 5/8:	-	M 22	M 22	-	7/8"
	M 24	-	-	M 24	M 24	-	15/16"
20 x 16	M 27	G 3/4"	-	M 27	M 27	-	1"
22 x 18	M 30	G 7/8"	-	M 30	M 30	-	1 1/8"
25 x 20	M 33	G 1"	-	M 33	M 33	-	1 1/4"
28 x 22	M 36	G 1 1/8"	-	M 36	M 36	-	1 3/8"
32 x 24	M 39	G 1 1/8"	-	M 39	M 39	-	1 1/2"
	M 42	-	-	M 42	M 42	-	1 5/8"
36 x 29	M 45	G 3/8"	-	M 45	M 45	-	13/4"
	M 48	G 1 1/2"	-	M 48	M 48	-	1 7/8"
	-	G 1 3/4"	-	-	-	-	-
	-	G 2"	-	-	-	-	-

Recommended Torque Values For Safety Clutch adjustment For Tapping & Cold Forming (Rolling)

For material upto 1000 N/mm²

Torque Setting Nm	Threads										Torque Setting Nm
	Metric	Whitworth BSW	BSP Whitworth Pipe	BSF	BSP Taper	BA	PG	NPT Taper	UNC	UNF	
1000	M 52				2 1/2 "						1000
1100											1100
1250	M 56	2 "							2 "		1250
1400				3 "	3 "			2 1/2 "			1400
2000		2 1/4 "						3 "			2000
2200		2 1/2 "									2200

The given torque values are for tapping & cold forming operations. They pertain to material with a tensile strength of 1000 N/mm².
 The torque values for tapping include a wear factor of 100%.
 If necessary, these values can be increased by up to 20% for tapping & up to 50% for cold forming.

Tap Shank Dimensions (JIS Standards)

Dimension in mm. Dia. x Square		Tap Size
3.00	2.50	M 1, M 2.6
4.00	3.00	M 3, M 3.5
4.00	3.20	M 3, M 3.5
5.00	4.00	M 4, M 4.5
5.50	4.50	M 5, M 5.5
6.00	4.50	M 6, 1/4"UNC
6.10	5.00	5/16"UNC
6.20	5.00	M 7, M 8
7.00	5.50	M 9, M 10, 3/8"UNC
8.00	6.00	M 11, 7/16"UNC, 1/8"P
8.00	6.20	M 11, 1/8"BSP
8.50	6.50	M 12
9.00	7.00	1/2"UNC
9.50	7.00	M 13
10.50	8.00	M 14, M 15, 9/16"UNC
11.00	9.00	1/4"P
12.00	9.00	5/8"UNC
12.50	10.00	M 16
13.00	10.00	M 17
14.00	11.00	M 18, 3/4"UNC, 3/8"P
15.00	12.00	M 20
17.00	13.00	M 22, 7/8"UNC
18.00	14.00	1/2"P
19.00	15.00	M 24, M 25, 5/8"P
20.00	15.00	M 26, M 27, 1"UNC
21.00	17.00	M 28
22.00	17.00	1 1/8"UNC
23.00	17.00	M 30, 3/4"P
24.00	19.00	M 32, 7/8"UNC
25.00	19.00	M 33
26.00	21.00	M 34, M 35 1"P
28.00	21.00	M 36, M 38 1 1/8"P
30.00	23.00	M 39, M 40
32.00	26.00	M 42, 1 1/4"P
35.00	26.00	M 45, 1 3/8"P
38.00	29.00	M 48, 1 1/2"P
40.00	32.00	M 52, M 56 & 1 7/8"UNC, 2"UNC

Tap Shank Dimensions ANSI (US Standards)

Dimension in Inch. Dia. x Square		Metric Conversions		Tap Size
0.141	0.110	3.59	2.80	1/8" No.6
0.168	0.131	4.27	3.33	5/32" No.8
0.194	0.152	4.93	3.87	3/16" No. 10
0.220	0.165	5.59	4.20	No. 12
0.255	0.191	6.48	4.86	1/4" No. 14
0.313	0.234	7.94	5.95	1/16"Ps 1/8"Ps
0.318	0.238	8.08	6.05	5/16" 3/8"
0.323	0.242	8.21	6.15	5/16" 7/16"
0.367	0.275	9.33	6.99	1/2"
0.381	0.286	9.68	7.27	3/8"
0.429	0.322	10.90	8.18	9/16"
0.438	0.328	11.12	8.34	1/8"PLs
0.480	0.360	12.20	9.15	5/8"
0.542	0.406	13.77	10.31	11/16"
0.563	0.421	14.29	10.70	1/4"Ps
0.590	0.442	14.99	11.23	3/4"
0.652	0.489	16.57	12.43	M 20, 13/16"
0.688	0.515	17.47	13.09	1/2" Ps
0.697	0.523	17.71	13.29	7/8"
0.700	0.531	17.78	13.49	3/8"Ps
0.760	0.570	19.31	14.48	M 24, 15/16"
0.800	0.600	20.32	15.24	1"
0.896	0.672	22.76	17.07	1 1/8"
0.906	0.679	23.02	17.25	3/4"P
1.021	0.766	25.94	19.46	1 1/4"
1.108	0.831	28.15	21.11	1 3/8"
1.125	0.843	28.58	21.42	1"P
1.233	0.925	31.32	23.50	1 1/2"
1.313	0.984	33.34	25.00	1 1/4"P
1.430	1.072	36.33	27.23	1 3/4"
1.500	1.125	38.10	28.58	1 1/2"P
1.644	1.233	41.76	31.32	2"

Note: All Dimensions are in mm

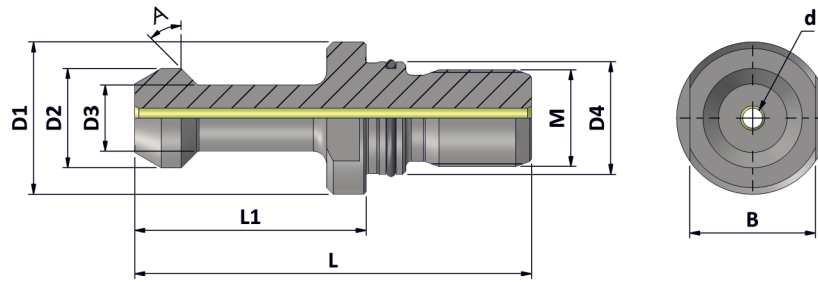
BT (MAS)

Item Name	Item Code	d	D1	D2	D3	D4	A	B	M	L	L1
PS BT30 45 DEG W/TC	K10195344311126	-	16.5	11	7	12.5	45	13	M12	43	23
PS BT30 60 DEG W/TC	K10195344312238	-	16.5	11	7	12.5	60	13	M12	43	23
PS BT30 90 DEG W/TC	K10195344313126	-	16.5	11	7	12.5	90	13	M12	43	23

PS BT40 45 DEG TC WITH O RING	K10195345311237	3	23	15	10	17	45	19	M16	60	35
PS BT40 45 DEG W/TC	K10195345311126	-	23	15	10	17	45	19	M16	60	35
PS BT40 45 DEG W/TC WITH O RING	K10195345311238	-	23	15	10	17	45	19	M16	60	35
PS BT40 60 DEG TC WITH O RING	K10195345312237	3	23	15	10	17	60	19	M16	60	35
PS BT40 60 DEG W/TC	K10195345312126	-	23	15	10	17	60	19	M16	60	35
PS BT40 60 DEG W/TC WITH O RING	K10195345312238	-	23	15	10	17	60	19	M16	60	35
PS BT40 90 DEG TC WITH O RING	K10195345313237	3	23	15	10	17	90	19	M16	60	35
PS BT40 90 DEG W/TC	K10195345313126	-	23	15	10	17	90	19	M16	60	35
PS BT40 90 DEG W/TC WITH O RING	K10195345313238	-	23	15	10	17	90	19	M16	60	35

PS BT50 45 DEG TC WITH O RING	K10195346311237	7	38	23	17	25	45	30	M24	85	45
PS BT50 45 DEG W/TC	K10195346311126	-	38	23	17	25	45	30	M24	85	45
PS BT50 45 DEG W/TC WITH O RING	K10195346311238	-	38	23	17	25	45	30	M24	85	45
PS BT50 60 DEG TC WITH O RING	K10195346312237	7	38	23	17	25	60	30	M24	85	45
PS BT50 60 DEG W/TC	K10195346312126	-	38	23	17	25	60	30	M24	85	45
PS BT50 60 DEG W/TC WITH O RING	K10195346312238	-	38	23	17	25	60	30	M24	85	45
PS BT50 90 DEG TC WITH O RING	K10195346313237	7	38	23	17	25	90	30	M24	85	45
PS BT50 90 DEG W/TC	K10195346313126	-	38	23	17	25	90	30	M24	85	45
PS BT50 90 DEG W/TC WITH O RING	K10195346313238	-	38	23	17	25	90	30	M24	85	45

Note: All Dimensions are in mm

Recommended Torque Values For Safety Clutch adjustment For Tapping & Cold Forming (Rolling)

For material upto 1000 N/mm²

Torque Setting Nm	Threads										Torque Setting Nm
	Metric	Whitworth BSW	BSP Whitworth Pipe	BSF	BSP Taper	BA	PG	NPT Taper	UNC	UNF	
0.5	M3	-	-	-	-	No. 7	-	-	-	-	0.5
0.6	-	-	-	-	-	No. 6	-	-	No. 3	No. 4	0.6
0.8	M 3.5	-	-	-	-	No. 5	-	-	No. 4	No. 5	0.8
1.0	-	1/8"	-	-	-	-	-	-	No. 5	-	1.0
1.2	-	-	-	-	-	No. 4	-	-	-	No. 6	1.2
1.6	M4	-	-	-	-	-	-	-	No. 6	No. 8	1.6
2.0	-	5/32"	-	-	-	No. 3	-	-	No. 8	-	2.0
2.5	M5	-	-	3/16"	-	No. 2	-	-	-	No. 10	2.5
3.0	-	-	-	-	-	-	-	-	-	No. 12	3.0
4.0	-	3/16"	-	7/32"	-	No. 1	-	-	No. 10	1/4"	4.0
5.0	M6	7/32"	-	1/4"	-	No. 0	-	-	No. 12	-	5.0
6.0	-	-	G 1/8"	9/32"	-	-	-	-	-	5/16"	6.0
8.0	-	1/4"	-	5/16"	-	-	-	-	1/4"	3/8"	8.0
10	M8	-	-	-	-	-	-	-	-	-	10
12	-	5/16"	-	3/8"	-	-	PG 7	-	5/16"	7/16"	12
16	-	-	-	-	-	-	-	-	-	1/2"	16
18	M10	3/8"	G 1/4"	7/16"	1/8"	-	-	-	3/8"	-	18
20	-	-	-	-	-	-	PG9	1/8"	-	-	20
22	-	-	-	-	-	-	PG11	-	-	9/16"	22
25	-	-	-	1/2"	-	-	PG 13.5	-	-	5/8"	25
28	M 12	7/16"	G 3/8"	-	-	-	PG 16	-	7/16"	-	28
32	-	-	-	9/16"	-	-	-	-	-	-	32
36	-	-	-	-	-	-	-	-	-	3/4"	36
40	-	-	-	5/8"	-	-	-	-	1/2"	-	40
45	M 14	1/2"	-	11/16"	-	-	PG 21	-	-	-	45
50	M 16	-	G 1/2"	-	1/4"	-	-	-	9/16"	-	50
56	-	-	G 5/8"	-	-	-	-	1/4"	-	7/8"	56
63	-	5/8"	-	-	3/8"	-	PG 29	-	5/8"	-	63
70	-	-	G 3/4"	3/4"	-0	-	-	3/8"	-	-	70
80	M 18	-	G 7/8"	13/16"	-	-	PG 36	-	-	-	80
90	M 20	3/4"	-	7/8"	-	-	PG 42	-	3/4"	1"	90
100	M22	-	-	-	-	-	PG 48	-	-	1 1/8"	100
110	-	-	-	-	-	-	-	-	-	1/4"	110
125	-	7/8"	-	1"	-	-	-	-	7/8"	1 3/8"	125
140	-	-	G 1"	-	-	-	-	-	-	1 1/2"	140
160	M24	-	G 1 1/8"	-	1/2"	-	-	1/2"	-	-	160
180	M 27	-	G 1 1/4"	1 1/8"	-	-	-	-	-	-	180
200	-	1"	G 1 3/8"	1 1/4"	3/4"	-	-	3/4"	1"	-	200
220	-	-	G 1 1/2"	-	-	-	-	-	-	-	220
240	-	-	G 1 3/4"	-	-	-	-	-	-	-	240
260	-	-	G 2"	1 3/8"	-	-	-	-	-	-	260
280	M 30	1 1/8"	-	-	-	-	-	-	1 1/8"	-	280
300	-	-	G 2 1/4"	1 1/2"	-	-	-	-	-	-	300
320	M 33	1 1/4"	-	1 5/8"	-	-	-	-	1 1/4"	-	320
340	-	-	G 2 1/4"	-	1"	-	-	1"	-	-	340
360	-	-	G 2 3/4"	-	-	-	-	-	-	-	360
400	-	-	G 3"	-	-	-	-	-	-	-	400
420	M 36	-	G 3 1/4"	-	-	-	-	-	-	-	420
450	-	-	G 3 1/2"	1 3/4"	1 1/4"	-	-	1 1/4"	-	-	450
480	M 39	1 3/8"	G 3 3/4"	-	-	-	-	-	1 3/8"	-	480
500	-	1 1/2"	G 4"	2"	-	-	-	-	1 1/2"	-	500
560	-	-	-	-	1 1/2"	-	-	1 1/2"	-	-	560
630	M 42	-	-	-	-	-	-	-	-	-	630
710	M 45	-	-	2 1/4"	2"	-	-	2"	-	-	710
800	-	1 5/8"	-	2 1/2"	-	-	-	-	-	-	800
900	M 48	1 3/4"	-	2 3/4"	-	-	-	-	1 3/4"	-	900

The given torque values are for tapping & cold forming operations. They pertain to material with a tensile strength of 1000 N/mm².

The torque values for tapping include a wear factor of 100%.

If necessary, these values can be increased by up to 20% for tapping & up to 50% for cold forming.

Note: All Dimensions are in mm

Continued...

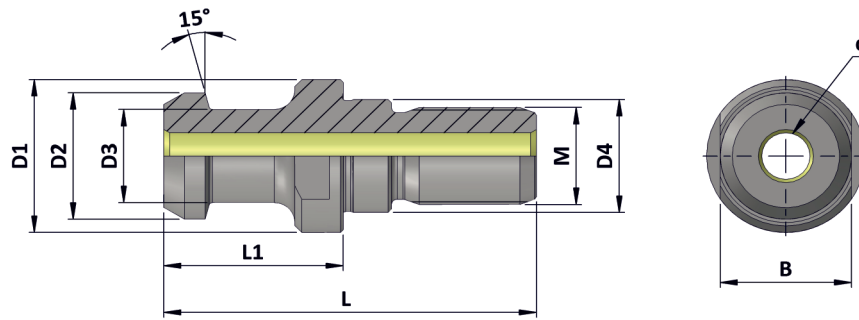
ISO 7388 A Pull Studs (PS)

Item Name	Item Code	d	D1	D2	D3	D4	B	M	L	L1
PS ISO40 A ISO7388 TC	K10195351309125	7.3	23	19	14	17	19	M16	54	26
PS ISO40 A ISO7388 W/TC	K10195351309126	-	23	19	14	17	19	M16	54	26

PS ISO50 A ISO7388 TC	K10195352309125	11.5	36	28	21	25	30	M24	74	34
PS ISO50 A ISO7388 W/TC	K10195352309126	-	36	28	21	25	30	M24	74	34

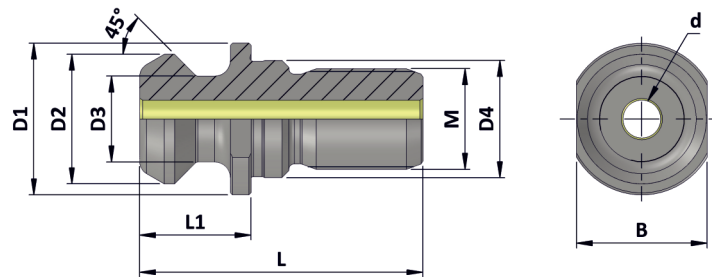
ISO 7388 B Pull Studs (PS)

Item Name	Item Code	d	D1	D2	D3	D4	B	M	L	L1
PS ISO40 B ISO7388 TC	K10195351310125	7.3	22.5	18.8	12.95	17	19	M16	44.5	16.4
PS ISO40 B ISO7388 W/TC	K10195351310126	-	22.5	18.8	12.95	17	19	M16	44.5	16.4

PS ISO50 B ISO7388 TC	K10195352310125	11.5	37	29.1	19.6	25	30	M24	65.5	25.5
PS ISO50 B ISO7388 W/TC	K10195352310126	-	37	29.1	19.6	25	30	M24	65.5	25.5

Note: All Dimensions are in mm

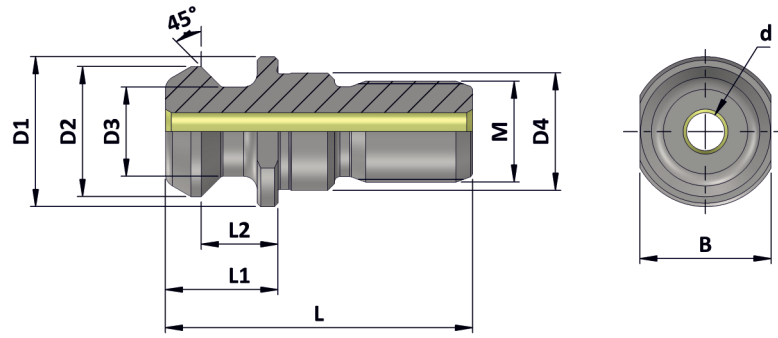
Mazak Pull Studs (PS)

Item Name	Item Code	d	D1	D2	D3	D4	B	M	L	L1	L2
PS MAZAK BT40 TC	K10195377320125	7	22	18.8	12.45	17	19	M16	44.10	19.10	14
PS MAZAK BT40 W/TC	K10195377320126	-	22	18.8	12.45	17	19	M16	44.10	19.10	14

PS MAZAK SK40 TC	K10195377321125	7	22	18.8	12.45	17	19	M16	41.10	16.10	11
PS MAZAK SK40 W/TC	K10195377321126	-	22	18.8	12.45	17	19	M16	41.10	16.10	11

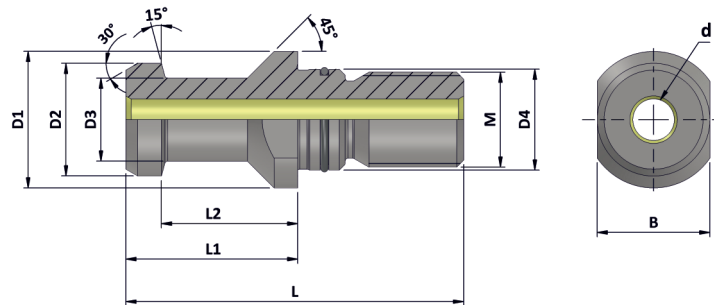
SK (DIN 69872-A) Pull Studs (PS)

Item Name	Item Code	d	D1	D2	D3	D4	B	M	L	L1	L2
PS SK30 A DIN 69872 W/TC WITH O RING	K10195610531238	-	17	13	9	13	14	M12	44	24	19

PS SK40 A DIN 69872 TC WITH O RING	K10195347531237	7	23	19	14	17	19	M16	54	26	20
PS SK40 A DIN 69872 W/TC WITH O RING	K10195347307238	-	23	19	14	17	19	M16	54	26	20

PS SK50 A DIN 69872 TC WITH O RING	K10195348531237	11.5	36	28	21	25	30	M24	74	34	25
PS SK50 A DIN 69872 W/TC WITH O RING	K10195348307238	-	36	28	21	25	30	M24	74	34	25

Note: All Dimensions are in mm

